

Double-Hung Replacement System Installation

The Pozzi Collection®

PID001 (12/03)

The Double-Hung Replacement System replaces the sash and balance system of an older double-hung window. The frame of the older window is left untouched. Refer to the appendix to verify the sash sizes are correct and the existing frame is square, level, and plumb. Read through and fully understand these instructions before beginning. If you have questions, call us or your dealer for assistance.

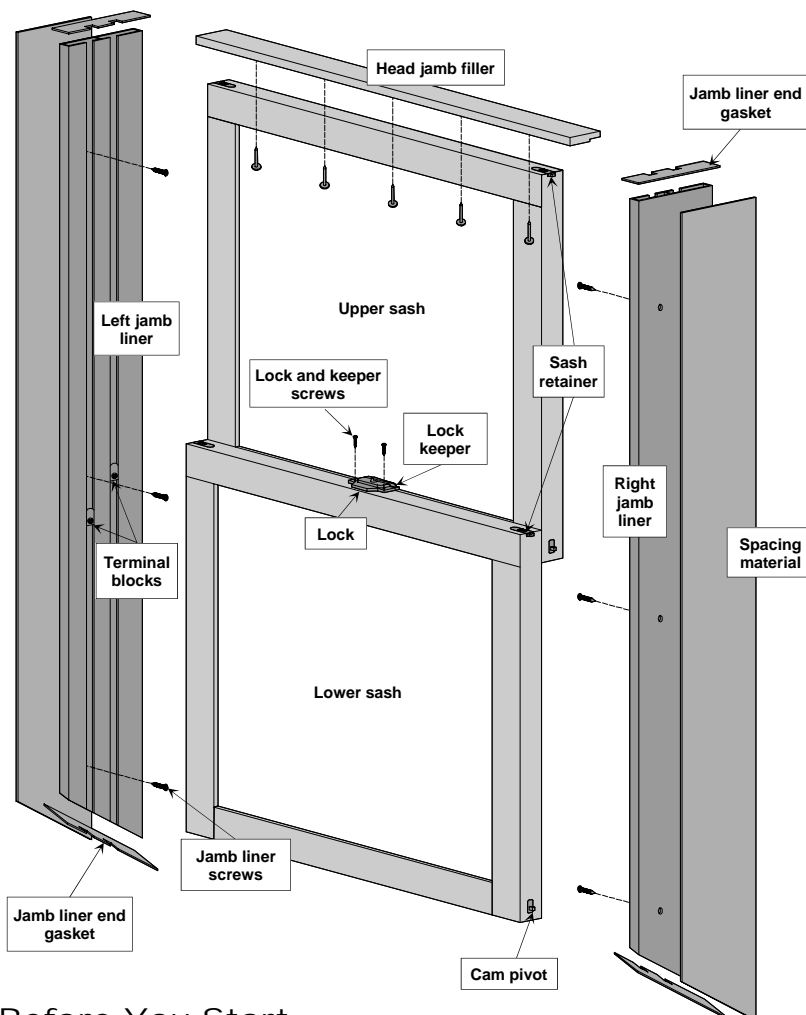

Parts List

- Upper Sash
- Lower Sash
- Head Jamb Filler
- Right Jamb Liner
- Left Jamb Liner
- Jamb Liner Screws (6)
- Cam Pivot (installed)
- Sash Retainer (installed)
- Spacing Material (2)
- Lock (not installed)
- Lock Keeper (not installed)
- Lock and Keeper Screws (4)
- Jamb Liner End Gaskets (2)

Materials Needed

- Small finish nails
- Pencil
- Drill
- Screwdriver with phillips bit
- Utility knife
- Hammer
- Silicone sealant
- Industrial strength scissors

Before You Start

- ▶ Familiarize yourself with the terminology and parts locations
- ▶ Check the contents of your Double-Hung Replacement System against the Parts List above
- ▶ The replacement sashes should be finished either before installation or immediately after (whichever is more convenient for you); finishing tips are provided in this document

Degree of Task Complexity

Do-It-Yourself  Technician

The advice offered herein can be done by a homeowner with some mechanical aptitude. If you are unsure, it is recommended that you hire a trained service provider such as a competent and licensed construction contractor or building professional. JELD-WEN disclaims any and all liability associated with the use and/or provision of these instructions. Any reliance upon the information or advice is at the risk of the party so relying. The information contained herein may be changed from time to time without notification.

Prepare Existing Window Frame

A double-hung balance system controls the tension and balance of the sashes to ensure smooth operation. Most double-hungs are equipped with either a weight and pulley balance system or jamb liners. The cords of a weight and pulley system are visible in the side jambs, while the jamb liner is a balance system concealed in a vinyl casing in the side jambs.

The new set of jamb liners will replace the balance system of the old window. Use care while removing the old sashes and balance to avoid injury. Remember, excessive force will break glass, so be careful.

For window with jamb liners,

- ▶ Remove upper and lower sashes and both jamb liners

For window with weight and pulley balance,

- 1 With a utility knife, carefully score inside stops (which run vertically on side jambs in front of lower sash) where they meet frame (fig. 1)
- 2 Gently pry off inside stops with putty knife; set aside for reuse; guard against damage
- 3 If old window has weight and pulley balance system,
 - With extreme caution, cut cords running to bottom sash and ease the weights down until cord goes slack; leave weights inside of frame; remove visible cords
 - If pulleys are visible in side jambs, remove them or use a hammer to carefully knock them through the jamb and fill the hole with loose-fill insulation
- 4 Remove lower sash
- 5 If present, score and remove jamb parting stops (fig. 1)
- 6 Support upper sash
- 7 If upper sash is fixed (non-moving),
 - Remove blocks or brackets that hold window in place; this will permit upper sash to be loweredIf upper sash is operational,
 - Cut cords running to sash and remove them from frame
- 8 Remove upper sash
- 9 Remove head parting stop (fig. 2) with a putty knife and discard (new head jamb filler will replace it)

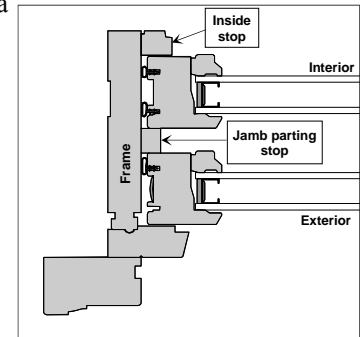

Fig. 1. Remove parting stops; horizontal cross-section; sash and jamb liners shown for reference

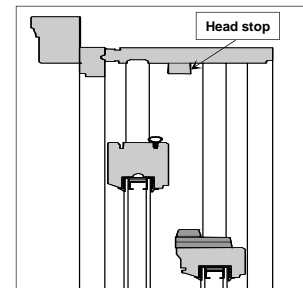

Fig. 2. Remove head stop

Install Replacement System

Refer to page 1 for parts identification.

- 1 Apply the four gaskets to jamb liners as shown on page 1
- 2 Position jamb liners into side jambs with angled end against sill to test the fit; remove

Note: As noted in "Parts List," spacer material is included in Double-Hung Replacement System. These thin sheets of foam fit behind jamb liners to adjust sash opening width. Place spacer material behind jamb liner as needed.
- 3 Apply a bead of silicone along the exterior side stops to seal the jamb liners in place
- 4 Install jamb liners; make sure there is a tight seal between the jamb liners and the exterior side stops
- 5 Secure jamb liners to frame with provided screws (jamb liners are drilled for screws) as shown in fig. 3
- 6 Position new head jamb filler (provided in your replacement pack) in place of the old head stop with weatherstrip facing exterior; trim new head jamb filler to fit frame, if necessary
- 7 Fasten head jamb filler with small finish nails (not provided)

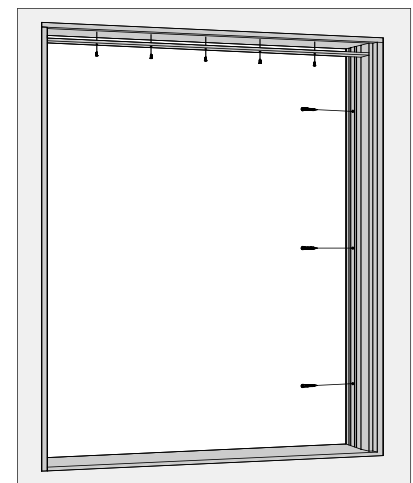

Fig. 3. Secure jamb liners and head jamb filler

8 Install upper sash into exterior channel of jamb liner as follows (figs. 4):

Note: Upper sash has lock keeper.

- Locate terminal blocks in jamb liners (see fig. 4)
- Hold sash horizontally with exterior facing up and cam pivots facing jamb liners
- Insert cam pivot of one corner of sash into exterior most channel of jamb liner *just above* terminal block
- Maneuver opposite cam pivot into opposite terminal block dropping in from above
- With sash horizontal, pull back both sash retainers and tilt sash into vertical position
- Lock into place by engaging sash retainers
- Close sash
- Test operation of sash by opening and closing

Note: If sash does not move freely in window frame, cam pivots may not be engaged properly. Remove and reinstall, taking care to engage cam pivots on both sides.

9 Install lower sash (as described above) into interior most channel of jamb liner and test sash operation

10 Line up keeper with pre-drilled holes in the bottom rail of the lower sash; screw into place

11 Place new lock on top rail of lower sash and align with lock keeper; lock into place

12 With pencil, mark lock screw hole locations; remove lock

13 Drill pilot hole at both pencil marks ($\frac{1}{4}$ " shorter than screw length)

Note: Drilling too deeply may destroy the insulating glass unit and would not be covered by the warranty.

14 Install lock; test operation; if not operating properly, contact us or a service provider for assistance

15 Replace inside stops that were removed

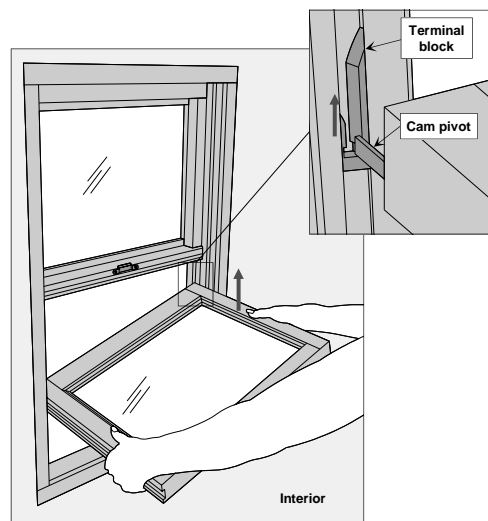

Fig. 4. Lift sash corner

Finishing Tips

It is necessary to paint or stain wood surfaces immediately after installation for protection against the elements. Failure to promptly finish and maintain the window units may affect future warranty claims. Below, we provide finishing tips. For more detailed information, refer to the ***Finishing & Refinishing Wood Windows and Patio Doors*** document in the *resources* section at www.jeld-wen.com/resources, or contact a paint professional.

- ▶ Set all nails below wood surface
- ▶ Fill all nail holes and finish bare wood surfaces immediately after installation
- ▶ Primed surfaces must be top coated within **21** days of delivery or the surfaces must be reprimed
- ▶ Be sure that all edges of the sash are sealed, but minimize the thickness of the paint or finish film on the edges of double-hung window sashes in contact with the jamb liners
- ▶ Do not paint or varnish the weatherstrip or operating hardware
- ▶ Be absolutely sure the sashes are completely dry before installing the sashes and closing the window
- ▶ Seek the advice of a local paint professional for finishing methods and products you select. The following represents typical approaches:
 - If staining (recommended only for interior surfaces),
 - Apply pre-stain conditioner if desired
 - Apply stain
 - When dry, sand all wood surfaces with a fine grit (**180-220**) sandpaper to remove raised grain and provide a smooth surface for the finish coats
 - Follow this with at least two coats of high quality, polyurethane finish
 - If painting,
 - Apply an appropriate primer for the type of paint being used
 - When dry, sand all wood surfaces with a fine grit (**180-220**) sandpaper to remove blemishes and provide a smooth surface for paint
 - Follow this with at least two coats of finish paint

Appendix: Window Frame Measurements

Inspect Window Frame (see Diagram)

Do not install the new replacement system until you are absolutely sure the existing window frame meets the following conditions. If not, seek professional assistance to determine how to correct. Refer to **Diagram** below.

- ▶ Frame must be square, level, and plumb
- ▶ Check existing sill and header for crowning or sagging; check side jambs for bow; see **Straightness** in the diagram to check for crowning, sagging, and bow
- ▶ The exterior face of the existing window must be in a single plane; see **Twist**
- ▶ Ensure sash opening is correct size for replacement pack you have purchased

Sill Angle

The standard double-hung sill slopes to the exterior at a **14°** angle. Use an angle finder (available in most hardware stores) or the cutout template in this appendix to verify the angle of the sill. If sill is another angle, specify the angle when ordering.

Height (fig. A1)

If necessary, to achieve head jamb to sill measurement, remove head stop (a wood trim that runs horizontally across the head jamb; see fig. 4) to take measurements. For single-hung windows (top sash does not move), support upper sash and remove blocks or brackets that hold upper sash in place; this will permit upper sash to be lowered.

Note: *The unsupported single-hung upper sash will fall. Use help if necessary.*

- 1 Open upper and lower sashes **6"**
- 2 String a tape measure between upper and lower sash
- 3 Take three measurements as follows:
 - Head to sill **4"** from left side jamb
 - Head to sill **4"** from right side jamb
 - Head to sill at midpoint
- 4 If all three measurements are within **1/8"**, write shortest measurement in "Height" column of measurements chart on the next page

Width (fig. A2)

- 1 Open lower sash **2"**
- 2 Measure width between jambs **4"** up from sill, **4"** down from head jamb, and at midpoint of window; if old windows have jamb liners, remove for measuring
- 3 If all three measurements are within **1/8"**, write narrowest measurement in "Width" column of measurements chart

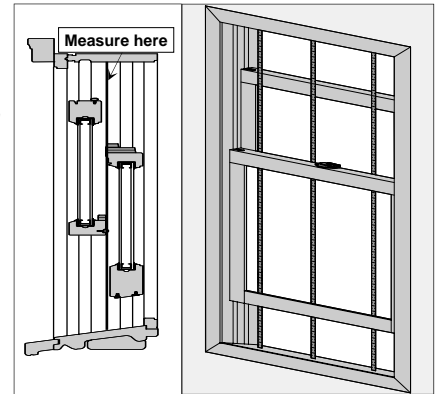

Fig. A1. Height measurement

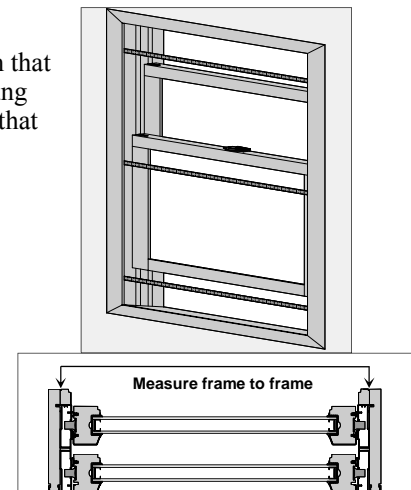
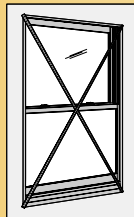

Fig. A2. Width measurement for existing

Diagram: Inspect the Existing Window

Square

- ▶ Measure from upper *left* corner to lower *right* corner of existing frame with tape measure
 - ▶ Measure from upper *right* corner to lower *left* corner; compare measurements
- If measurements are within **1/4"**, the frame is within tolerance; if more than **1/4"** difference, the frame is not within tolerance.



Level and Plumb

- Check existing frame for level**
- ▶ Place a level against the head jamb and check for level
- Check existing frame for plumb**
- ▶ Place a level against the side jamb and check for plumb

The allowable deviation for level and plumb is **1/16"** for every **2'** of length (not to exceed **1/8"**).

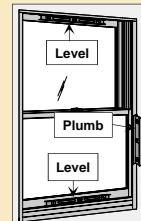

Straightness

(crowned, sagged or bowed)

Determine if head, sill and side jambs are straight as follows:

- ▶ Place a level or straight edge against jamb
- ▶ Look for gaps anywhere between level and jamb
- ▶ If gap is over **1/16"/2mm**, loosen or tighten adjustment screw in **1/4** turn increments

If the gap is greater than **1/16"/2mm** for every **2'** (not to exceed **1/8"/3mm**) the surface is not straight.

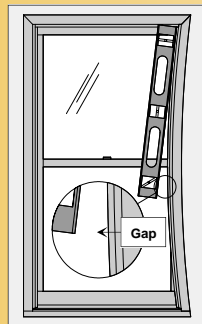

Twist

Check existing frame for **twist**.

- ▶ Cut two pieces of string several inches longer than the frame diagonals
 - ▶ Crisscross both pieces of string over existing frame and tape to all four corners
 - ▶ If there is a gap between strings at the cross point, measure it
 - ▶ If there is no gap between strings at cross point, repeat crisscross by placing top string underneath; measure any gap—the smaller the gap, the flatter the frame
- The maximum allowable gap is **3/16"/5mm**.

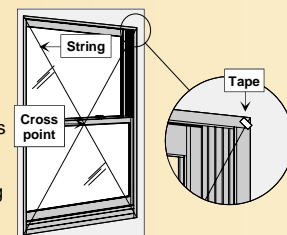

Window Frame Measurements

| Sill Angle | Height | Width | Location (for personal reference) |
|------------|------------------------------|-------------------------------|-----------------------------------|
| | Left | Top | |
| | Middle | Middle | |
| | Right | Bottom | |
| | Shortest Measurement: | Narrowest Measurement: | |
| | Left | Top | |
| | Middle | Middle | |
| | Right | Bottom | |
| | Shortest Measurement: | Narrowest Measurement: | |
| | Left | Top | |
| | Middle | Middle | |
| | Right | Bottom | |
| | Shortest Measurement: | Narrowest Measurement: | |
| | Left | Top | |
| | Middle | Middle | |
| | Right | Bottom | |
| | Shortest Measurement: | Narrowest Measurement: | |

Cutout Templates for Checking Sill Angle

