



This guide contains procedures for common user serviceable repair tasks found on wood horizontal operating windows. If a condition arises that is not covered in this guide, please contact us for professional help. This product guide covers our current JELD-WEN Custom, Premium and Builders Series windows as well as our historical products with the following names: Pozzi, Caradco and Norco. For help identifying your window model, refer to your product purchase paperwork or call us for additional help.

Do-It-Yourself

Technician



## INTRODUCTION

Horizontal sliding/gliding windows consist of two side-by-side sashes, one is a fixed sash and one is an operating sash (options also include a three sash window with a fixed sash in the middle and an operating sash on either side). The fixed sash does not move, and the operating sash moves back and forth horizontally to open and close. An insect screen is mounted on the exterior side of the operating sash(es).

### CONTACT US

For questions, feel free to contact us by phone or email:

- Email: [customerserviceagents@jeld-wen.com](mailto:customerserviceagents@jeld-wen.com)
- Phone: 1-(800)-JELD-WEN/1-(800)-535-3936

### TABLE OF CONTENTS

Precautions and Safety .....	2
Needed Materials & Tools.....	2
Sash Removal and Installation.....	2
Hardware Replacement and Adjustment .....	4
Lock Replacement & Adjustment.....	4
Weatherstrip Replacement.....	4
Sash Pull Installation .....	5
Sash Latch Replacement .....	5
Cladding Replacement.....	5
Proper Window Installation .....	6
Troubleshooting Operational Problems .....	7
Glossary.....	8

### SLIDING/GLIDING WINDOW ANATOMY

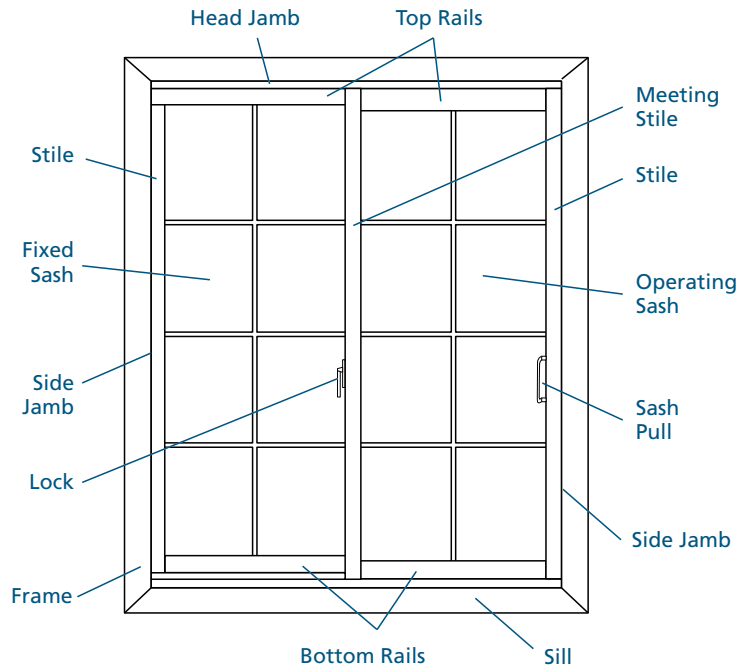

The advice offered herein can be done by a homeowner with some mechanical aptitude. If you are unsure, it is recommended that you hire a trained service provider such as a competent and licensed construction contractor or building professional. JELD-WEN disclaims any and all liability associated with the use and/or provision of these instructions. Any reliance upon the information or advice is at the risk of the party so relying. The information contained herein may be changed from time to time without notification.

## PRECAUTIONS & SAFETY

- Follow all manufacturers' instructions and labels.
- Use proper and safe equipment and precautions if servicing the exterior side of windows above ground level.
- Window insect screens are not security devices and will not prevent children, other people, or pets from falling through.
- Use extra care when driving screws near glass unit to avoid breakage.

- Use caution when tightening screws to avoid stripping the screw holes.
- Sash removal can be awkward and could cause physical injury or product damage; we recommend the help of a second person.

## NEEDED MATERIALS & TOOLS

### TOOLS

**Note!** Each tool is not required for every task.

- Tape measure
- Square
- Screwdrivers
- Prying tool
- Level
- Utility knife
- Hammer
- Drill with bits

### MATERIALS

- Silicone sealant for stationary sash reinstallation
- String
- Tape
- For screw hole repair:
  - Wooden toothpicks or dowels
  - Wood glue
- Fine sandpaper
- Finishing supplies

## SASH REMOVAL & INSTALLATION

The following section explains how to remove and replace the sashes in horizontal sliding/gliding windows. The most apparent difference between the two products is that the gliding window operating sash has sash tilt latches on both top corners, and the sliding window does not. Identify and familiarize yourself with the specific product features before beginning.

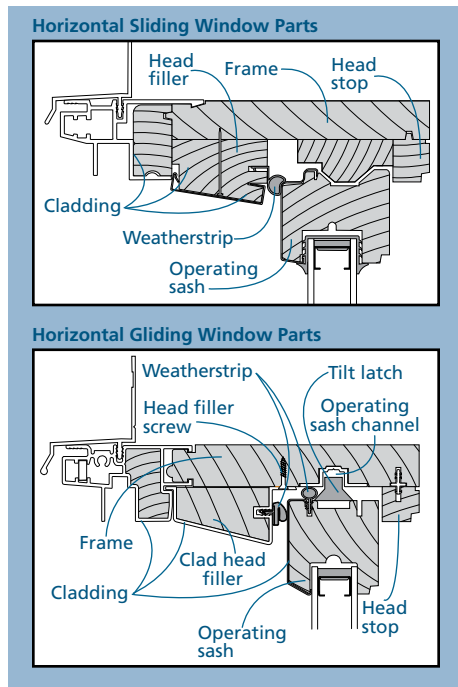

### OPERATING SASH REMOVAL & INSTALLATION

Sash removal procedures vary. If you need assistance, contact us. The operating sash may have retainer latches on both top corners.

#### For windows without retainer latches:

Unlock and open interior sash, grip firmly on both sides and lift up and over lower sill track. Most sashes remove from the interior. Some windows manufactured between 1984 and 1986 remove from the exterior.

#### For windows with retainer latches:

1. Unlock sash.
2. At top, score head stop (if necessary) with utility knife and remove.
3. Slide sash to center of window unit.
4. Press down latches on both sides of top of sash to release it from top track.
5. Tilt sash top out of top track, lift sash up then out of bottom track.
6. To install the operating sash, reverse the removal steps.

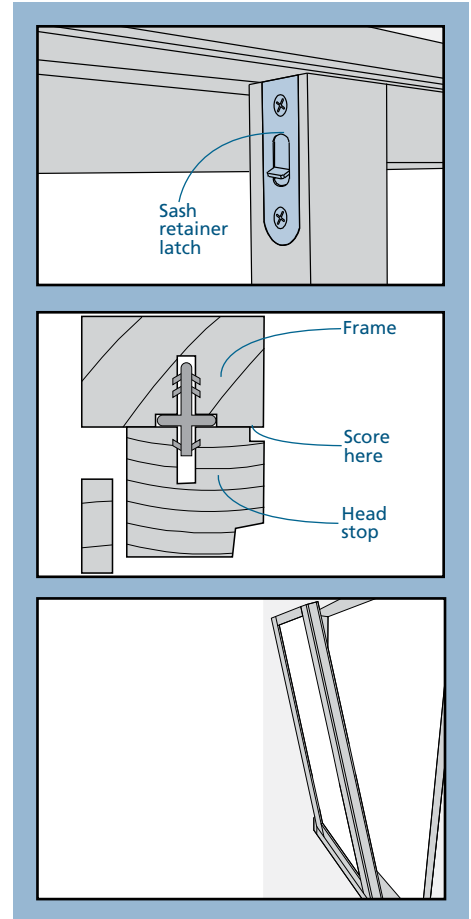

### NEW SASH INSPECTION & PREPARATION

1. Inspect sash for proper size and type, and for any damage; do not install if damaged.
  2. Paint and/or finish new sash upon delivery and let dry completely before installing hardware.
  3. Remove hardware (lock, keeper, and handle) from old sash and transfer to new sash.
- Very Important!** All hardware must be installed on new sash in exact positions as on the old sash. If necessary, measure and mark all hardware positions on new sash.
4. Determine hardware locations on new sash; pay close attention to lock and keeper alignment position.
  5. Pre-drill screw holes for hardware with 1/16" drill bit.
  6. Install hardware (previously removed from old sash) onto new sash.

SASH REMOVAL & INSTALLATION - CONTINUED

STATIONARY SASH STATIONARY SASH REMOVAL & INSTALLATION

Removal

**Note!** Stationary sashes can only be removed if the glass is not direct set (fixed directly to the frame). If you have a window with glass directly fixed to the frame, please call us for assistance. The operating sash must be removed before the stationary sash and the stationary sash must be installed before the operating sash. Securely hold sash while removing screws to prevent the sash from falling and becoming damaged or causing injury.

- At top, remove the plastic screen stop if present and head filler. If attached with nails, carefully score head filler edges with utility knife, then loosen with prying tool and remove. If attached with screws, unscrew and remove head filler.

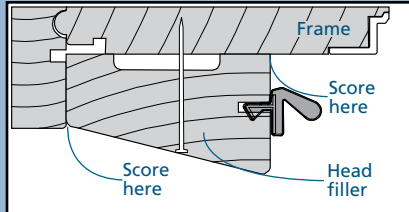

Window with a Sash Riser

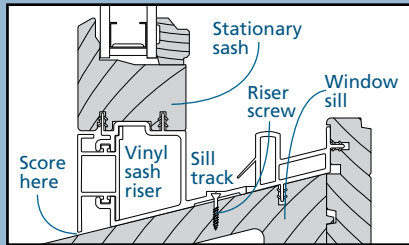

Window with a Sill Extender

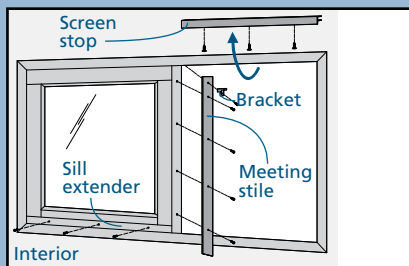
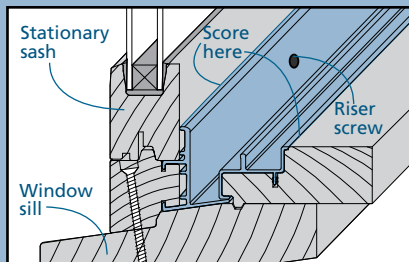

- Some windows will have a sash riser or a sill extender. Score through any paint film between the riser/extender and sill (interior and/or exterior); do not score cladding.
- For windows with a sill extender:
  - Unscrew and remove bracket from top of meeting stile.
  - Unscrew and remove meeting stile cover.
- Remove riser/extender screws (may be covered with wood putty or paint) from sill track. Riser is attached to the sash and will remove with the sash.
- For windows with sash retainer latches only: Unfasten top of sash by removing the screw and bracket holding sash to top track.
- Slide sash towards center of opening (if sash has been secured with sealant, carefully pry under riser with putty knife to help loosen sealant; use caution to avoid scratching wood surface).

- Tilt sash bottom outward (towards the exterior), the top inward (towards the interior), and remove; save all screws/nails for reinstallation.

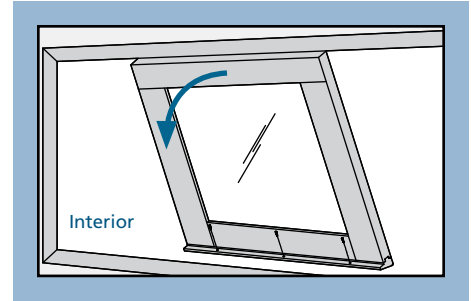

- If installing a new stationary sash that does not have a riser:
  - Unscrew riser from bottom of old sash and remove.
  - Remove any old tape or sealant material from bottom of riser and clean surface.
  - Follow new sash inspection and preparation instructions above.
- Pre-drill screw holes into bottom of new sash at appropriate locations with a 1/16" drill bit and attach riser to new sash.

Installation

- Apply a bead of silicone sealant across the sill where the sash riser will sit (especially at screw locations). Clean smeared sealant immediately!
- Position sash as close to the stationary side jamb as possible. With top tilted to the interior and bottom tilted to the exterior, place sash into frame.
- Fit top of sash into exterior-most top track.
- Without smearing sealant, pull sash bottom into the sill on the sealant.
- Slide sash tightly back into position against the side jamb where it was located before removal.
- Reattach bracket into top track with screw (if applicable).
- Reattach riser to sill with screws previously set aside.
- Reattach head filler as follows:
 

For wood head filler:

  - Reattach with nails (if nails are still inside head filler, align to previous nail holes and gently hammer to reattach; make sure nails are tight).

For clad wood head filler:

  - Slide cladding off unattached head filler.
  - Reattach head filler to its previous position with same nails.
  - Reattach cladding to head filler (slip interior side edge into kerf and then snap exterior edge in place).
- Install operating sash.
- Touch up finish as needed.

## HARDWARE REPLACEMENT & ADJUSTMENT

**Note!** Hardware styles have changed over the years and may vary slightly from the illustrations in this document.

### HARDWARE TYPES

- Metal hardware offers functionality, aesthetic appeal and resistance to corrosion but is not totally corrosion proof. Replace any hardware if it becomes corroded.
- Plastic hardware offers high resistance to the elements however, over time it can deteriorate from ultraviolet light, heat, cold, and chemical exposure.
- Brass hardware has a special protective film to reduce/eliminate polishing and requires special care.

Screw hole repair and hardware alignment, or realignment, are common tasks for any hardware replacement component. Follow these instructions if screw holes become stripped and/or if hardware no longer functions properly due to misalignment.

### SCREW HOLE REPAIR

1. Cut wooden toothpicks or appropriate sized wood dowel to fit screw hole just below wood surface.
2. Fill screw hole with wood glue.
3. Insert toothpicks or dowel; let dry.
4. Fill to surface with wood putty; let dry.
5. Sand smooth and refinish; let dry.
6. Drill new pilot hole.

### HARDWARE ALIGNMENT

Misalignment can happen if screws have become stripped and cannot be tightened. This alignment will create new screw holes.

1. Remove hardware.
2. Repair screw holes according to the procedure above.
3. Mark new screw holes as follows:
  - Lay hardware in position and hold in place.
  - If replacing a lock, turn latch to lock position to engage keeper.
  - Mark new screw locations through screw holes.
  - Remove hardware and set aside.
4. Drill pilot holes with 1/16" drill bit at new marked screw hole positions no deeper than screw length.
5. Install hardware.
6. Test operation; if not operating properly, call us for assistance.

### LOCK REPLACEMENT & ADJUSTMENT

Different lock styles were used during different periods of manufacture. If old lock and keeper were aligned correctly, the new lock and keeper should be aligned correctly through the same screw holes. If not, follow the steps above to realign hardware and re-install.

1. Unlock and open sash.
2. Unscrew and remove old lock and keeper.
3. Install new lock and keeper in the same place.
4. Test operation.

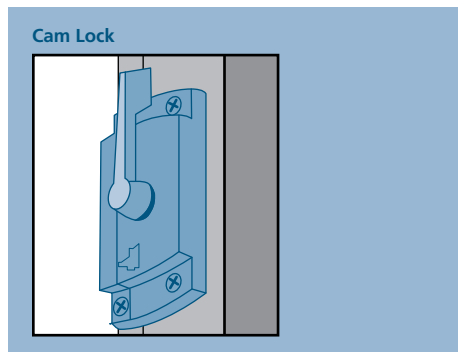

### WEATHERSTRIP REPLACEMENT

Inspecting and maintaining weatherstrip can help avoid costly structural damage from water leakage and energy loss due to air and/or water infiltration. Replace weatherstrip, that is missing, torn, cracked, brittle, discolored, gummy, or that has no "bounce back" when pressed down.

**Note!** When ordering, ask for the same weatherstrip type you have. If the original is not available, a suitable substitute may be provided.

Determine amount and type needed:

1. Measure each piece needing replacement; add 2" to each measurement.
2. Add all measurements, then add an additional 10%.
3. Round up to the nearest foot.
4. Call us to order new weatherstrip.
5. If painting the sash after weatherstrip removal, make sure paint is completely dry before installing new weatherstrip.
6. Remove sash.
7. Grip and gently pull existing weatherstrip from kerf.

**Note!** On some windows, there are two kerfs in the top and bottom rails; on the top rail, the weatherstrip goes in the interior kerf; on the bottom rail, the weatherstrip goes in the exterior kerf. On the Smart Fit, weatherstrip is located in the head jamb, check rail, and the sill.

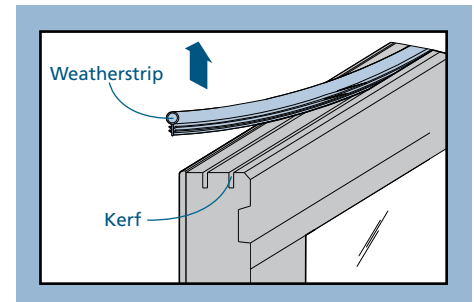

8. Cut new weatherstrip to length of existing weatherstrip + 1".

For sash corners:

9. Press new weatherstrip into kerf with 1/2" extending past each corner.
10. Trim each piece at corners the same as old weatherstrip (either at a 45° or 90° angle to fit tightly at the corners).

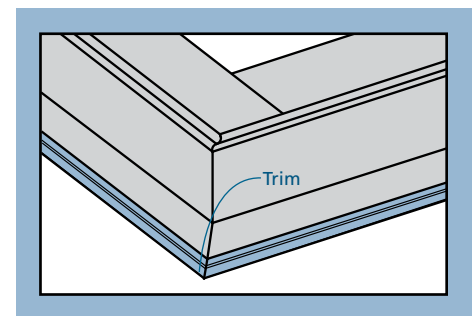

For frame:

11. Press new weatherstrip into horizontal kerf at top and/or bottom of frame and trim 90° at each end.
12. Press new weatherstrip into vertical kerf overlapping horizontal weatherstrip 1" for trimming.
13. Trim vertical piece to overlap horizontal piece.
14. Reinstall sash.
15. Check window operation, if not operating correctly, remove and reinstall weatherstrip. If unsuccessful, call us for recommendations.

HARDWARE REPLACEMENT & ADJUSTMENT - CONTINUED

SASH PULL (HANDLE) INSTALLATION

1. Align sash pull slightly off horizontal center and at vertical center of closing stile (the stile that closes against the side jamb).

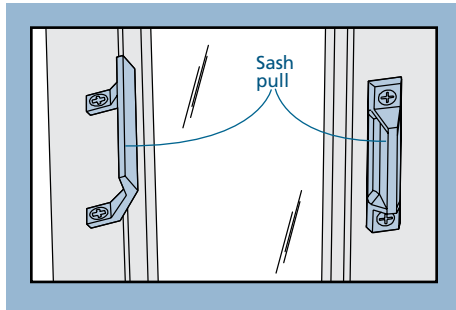

**Note!** Do not place sash pull with screw holes within 1" of the visible glass.

2. Mark stile through sash pull screw holes.
3. Remove sash pull and drill pilot holes where marked with 1/16" drill bit slightly shallower than screw length.
4. Align sash pull with pilot holes and secure with screws.

SASH LATCH REPLACEMENT

1. Unscrew and remove latch.
2. Position new latch in same place and secure screws.

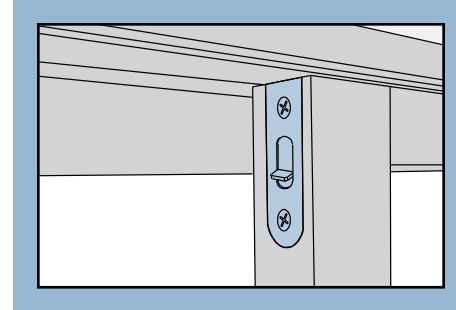

CLADDING REPLACEMENT

Stile or rail cladding may be replaced on boot-glazed windows only.

1. Remove sash.

**Note!** Cladding may be secured with either staples or sealant.

2. If secured with staples, pry off staples with stiff putty knife.
3. If secured with sealant, pry cladding with stiff smooth tipped putty knife beginning at corner to loosen; do not scratch wood surfaces.
4. Slide old cladding off (if necessary, pry edge with putty knife with care to avoid damage to wood surfaces).
5. Snap new cladding onto stile/rail with shorter side in the kerf on the weatherstrip side.

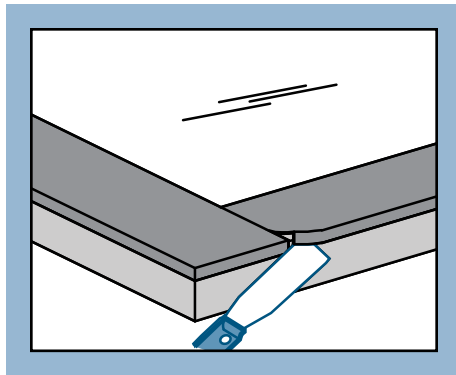

6. If necessary, tap the end down with a rubber mallet and secure with a small staple or 1" brad nail.
7. Prepare new stile/rail by drilling any necessary screw holes with 3/32" drill bit 1/4" shallower than screw lengths for screws and/or hardware (locate new screw locations by comparison to old sash), and transfer any hardware.
8. Reassemble sash.
9. Apply finish/paint and let completely dry before replacing sash.
10. Reinstall sash.

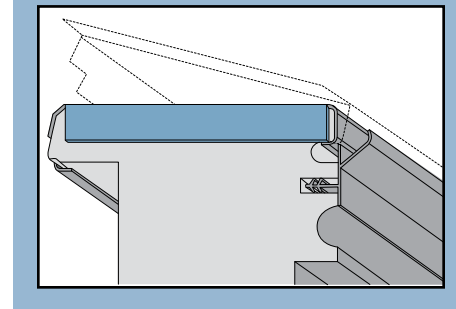
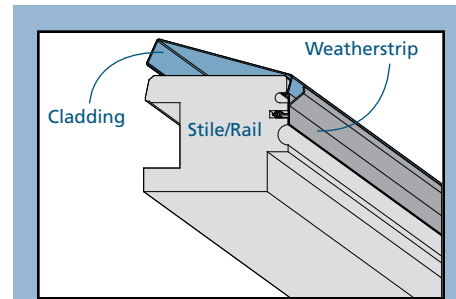

**PROPER WINDOW INSTALLATION**

- Proper installation is essential for keeping windows operating smoothly. If a window fails to operate properly, an inspection is necessary to determine if it was installed correctly.
- These inspection instructions apply to flat window types. Bow windows, bay windows, and unusual geometric-shaped windows are more complicated and should be inspected by a window professional.
- A contractor or installer can assist in determining the cause of a window being “out of specification” and possibly correct it. Window problems due to improper installation are usually not covered by the manufacturer’s warranty. For installation instructions, contact us or your supplier.
- The specifications and measurements referenced in this guide are taken from ASTM E2112 Standard Practice for Installation of Exterior Windows, Doors and Skylights.

**Note:** These instructions do not address inspection for proper “water tightness” or flashing. A “water tight” inspection requires removal of the exterior siding around the window. Seek professional assistance regarding this issue.

**LEVEL INDICATOR**

Accurate measurements are essential in determining level and plumb. Most carpenters' levels have several bubble level indicators, making it possible to measure all parts of the window. Examine the horizontal indicator. If the bubble is centered between the lines of the indicator, it is level. If the bubble is not exactly centered, measure how far “out of level” or “out of plumb” by maneuvering the end of the level until the bubble is exactly centered. Measure the farthest gap between the level and the surface. On a 2' level, the gap must not exceed 1/16", or on a 4' level (or longer), the gap must not exceed 1/8", or the surface is out of level/plumb.

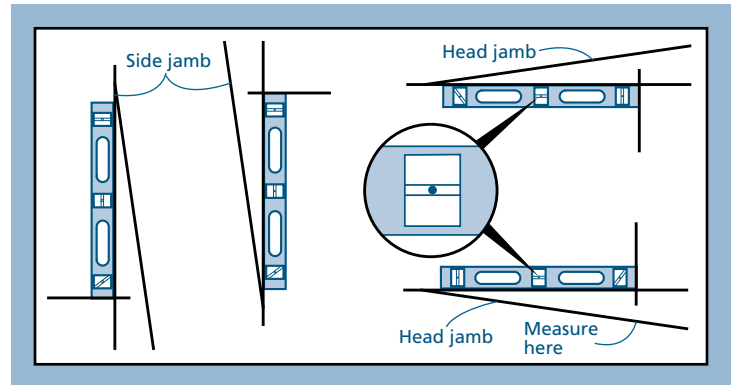

**SQUARE**

Measure frame/sash from top left to bottom right corner and from top right to bottom left corner. If measurements differ by 1/8" for windows up to 20 sq. ft. or 1/4" for windows larger than 20 sq.ft., unit is out-of-square.

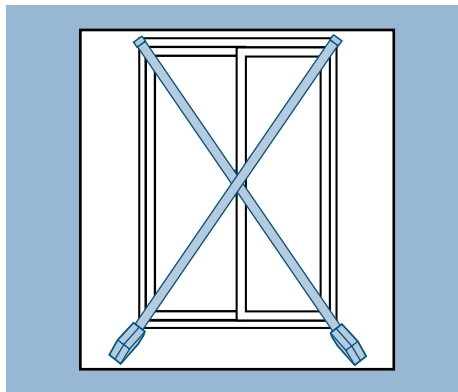

**FRAME TWISTS**

Attach two pieces of string to frame/sash, corner to corner. If there is a gap between strings at center point larger than 1/8" for windows up to 4' wide or high, or 3/16" for windows larger than 4' wide or high, the frame is not flat. Repeat by switching strings and re-measuring.

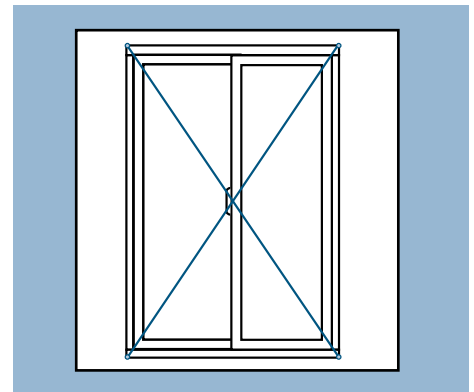

**LEVEL AND PLUMB**

For plumb, place level against each side jamb or use a plumb bob. For level, place level against head jamb and sill.

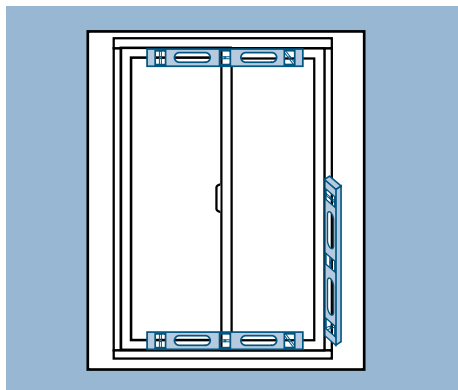

**PROPER SHIMMING**

Measure width of frame at top, center, and bottom. If any two measurements differ more than 1/16", the frame is over or under shimmed. Repeat process and measure height of frame.

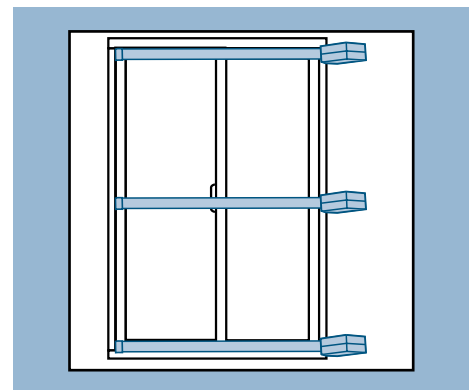

PROPER WINDOW INSTALLATION - CONTINUED

STRAIGHT SIDE JAMBS

Place level against inside of side jamb. Look for gaps anywhere between level and side jamb. Repeat steps for other side jamb.

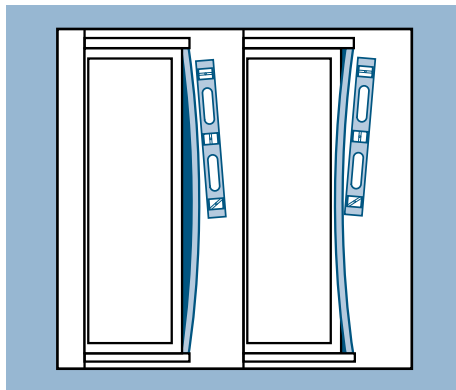

FRAME/PANEL BOW

Inspect interior and exterior frame jambs, or stiles/rails of panel (not glass) to determine if bowed.

1. Cut piece of string slightly longer than height of frame or panel.
2. Pull tightly and stretch string to upper and lower corners of jambs, or, stiles or rails of panel. Tape securely.

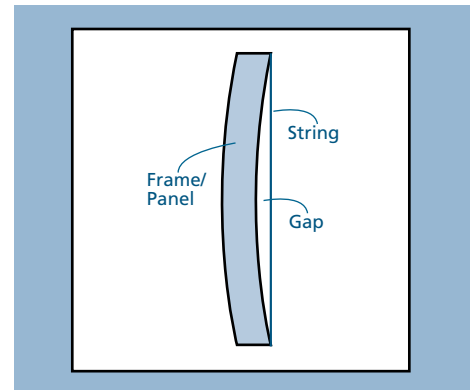

3. Look for gap between string and frame or panel. If gap measures more than 1/16" at any point, the panel is bowed.

TROUBLESHOOTING OPERATIONAL PROBLEMS

**Note!** Please check each possible cause, including verifying proper installation, before contacting us for assistance.

PROBLEM	POSSIBLE CAUSES	POSSIBLE SOLUTIONS
Sash will not open	Sash locked	Make sure lock latch is in unlocked position, try again
	Sash is stuck, finished or painted shut to the frame or weatherstrip.	<ul style="list-style-type: none"> <li>• Grip sash and gently shake to loosen.</li> </ul> If these solutions do not solve the problem: <ul style="list-style-type: none"> <li>• Carefully score along paint line with utility knife.</li> </ul> After sash is loose, if necessary, clean weatherstrip with small amount denatured alcohol (do not use on fuzzy weatherstrip).
	Obstructions	Remove obstructions/shipping blocks
	Sash damaged	Repair or replace sash
	Lock damaged or broken	Replace lock
	Keeper loose or damaged	Tighten if loose, replace if damaged
	Weatherstrip loose or damaged	Reattach If loose, replace if damaged
Improper installation	Inspect installation	
Sash will not close	Sash locked	Make sure lock latch is in unlocked position, try again.
	Obstructions	Remove obstructions/shipping blocks.
	Keeper loose or damaged	Reattach If loose, replace if damaged
	Weatherstrip loose or damaged	Reattach If loose, replace if damaged
	Improper installation	Inspect installation
Sash binds or drags	Sill track dirty	Clean sill track then lubricate with silicone spray on a cloth
	Obstructions	Remove obstructions/shipping blocks
	Weatherstrip loose or damaged	Reattach if loose, replace if damaged
	Improper installation	Inspect installation
Sash will not lock properly	Lock misaligned or damaged	Realign if misaligned, replace if damaged
	Improper installation	Inspect installation.

PROBLEM	POSSIBLE CAUSES	POSSIBLE SOLUTIONS
The window surface fogs up	Condensation. See also our condensation document at: <a href="http://www.jeld-wen.com/_pdf/JG1012.pdf">http://www.jeld-wen.com/_pdf/JG1012.pdf</a>	<p>If condensation is on an interior surface:</p> <ul style="list-style-type: none"> <li>• Raise the average temperature of the house one or two degrees and do not block vents.</li> <li>• Vent all appliances to the outdoors and run exhaust fans.</li> <li>• Open window blinds for air circulation.</li> <li>• Turn humidifiers down as the temperature gets colder (unless used for medical purposes).</li> </ul> <p>If condensation is on an exterior surface:</p> <ul style="list-style-type: none"> <li>• Close window coverings to reduce cooling of the glass surface by air-conditioning.</li> <li>• Remove or trim shrubbery close to windows to promote air circulation.</li> </ul> <p>If condensation is between glass panes:</p> <ul style="list-style-type: none"> <li>• Seal failure. Replace either the insulating glass assembly or the entire sash. This determination should be made by a service representative.</li> </ul>
Sash appears crooked in frame	Obstructions	Remove obstructions/shipping blocks
	Improper installation	Inspect installation
Water leaks through the window	Weatherstrip damaged or missing	Reattach if loose, replace if damaged
Metal cladding is dull	Cladding is dirty or oxidized.	<ul style="list-style-type: none"> <li>• Rinse with water from bottom to top to bottom to prevent dirty run-down and streaking. If needed, use a soft bristle brush while rinsing.</li> <li>• Air or wipe dry with chamois or soft, lint-free, dry cloth.</li> </ul> <p>Apply high quality, non-abrasive car wax to clad surface for protective finish (follow wax manufacturer's instructions).</p>

## GLOSSARY

### Cam Lock

A single-point locking mechanism that uses a "cam" action to lock and to pull the window sash against the frame forming a tight weather seal; large windows may have more than one cam lock.

### Direct-Set

The window's glass is secured directly into the window frame without the stiles and rails of a sash.

### Head Filler

A trim piece in the header of a horizontal sliding window used to provide a weatherstrip seal for the operating sash.

### Head Stop

A trim piece at the head of the window against the interior side of the sash.

### Jamb

The vertical frame members of a window or patio door assembly.

### Keeper

A bracket utilized as a latching point for locking systems.

### Kerf

A groove that often holds weatherstrip.

### Riser

The structural component fixed to the bottom of the stationary sash that rests on the window sill.

### Sash

An assembly comprised of stiles (vertical pieces), rails (horizontal pieces) and the window's glass.

### Sash Latch

A latch located at the top of the both stiles of a horizontal gliding window sash that secures the sash into the track; the sash latches are released to remove the sash.

### Score

To inscribe a line with a sharp instrument.

### Screen Plunger

A spring loaded pin in an insect screen that holds it in place.

### Screen Stop

A trim piece that holds the screen in place.

### Sill Track

The track on the sill of a sliding/gliding window or patio door that guides the sash as it opens and closes.

### Weatherstrip

A strip of material that covers the joint between two separate parts of a window or patio door and is used to prevent rain, snow, and cold air from entering.