



This guide provides important information that will help keep wood windows and patio doors looking beautiful and operating smoothly for many years while maintaining warranty coverage. Regular inspections and minor maintenance are the best ways to keep these products in good condition.

Do-It-Yourself

Technician



INTRODUCTION

For optimal performance, new wood products should be finished or painted as soon as possible after installation. Finishing is necessary because by nature, wood is porous. Painting and finishing seals porous surfaces, maintains, protects and enhances the beauty of the product by keeping it less susceptible to debris and easier to clean. Keeping wood properly finished is the first step in effective maintenance.

TABLE OF CONTENTS

Precautions and Safety	2
Needed Materials & Tools	2
Basic Inspections & Maintenance	3
Cleaning Glass	4
Hardware Cleaning & Lubrication	5
Cleaning Wood & Cladding	7
Finishing & Refinishing	8
Glossary	11
Inspection Checklist	12

CONTACT US

- For questions, feel free to contact us by phone or email:
- Email: customerserviceagents@jeld-wen.com
 - Phone: 1-(800)-JELD-WEN/1-(800)-535-3936

WINDOW & PATIO DOOR PARTS

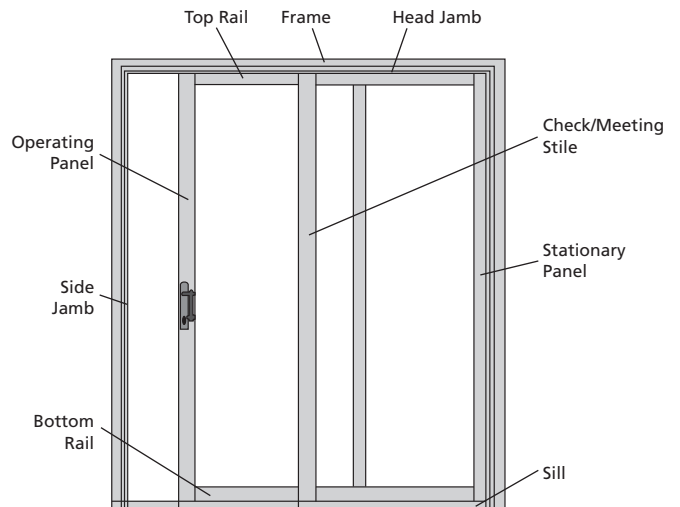
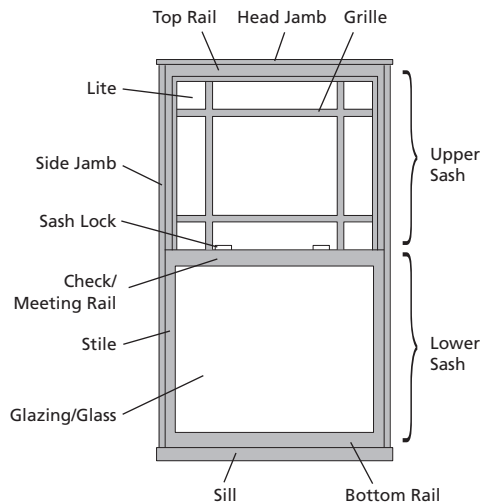

The advice offered herein can be done by a homeowner with some mechanical aptitude. If you are unsure, it is recommended that you hire a trained service provider such as a competent and licensed construction contractor or building professional. JELD-WEN disclaims any and all liability associated with the use and/or provision of these instructions. Any reliance upon the information or advice is at the risk of the party so relying. The information contained herein may be changed from time to time without notification.

PRECAUTIONS, SAFETY & CLEANING RECOMMENDATIONS

PRECAUTIONS & SAFETY

- Window insect screens are not security devices and will not prevent a child or anyone from falling through.
- Never mix cleaners or solvents. This may be dangerous as well as ineffective.
- Use help when working with a large window sash or patio door panel to avoid injury.
- Use proper/safe equipment and precautions when cleaning and servicing the exterior side of windows above ground level.
- If using commercial cleaning or finishing products or solvents, carefully read and follow safety instructions, warnings, cautions and disposal instructions on manufacturer's labels. Wear appropriate safety gear (e.g. clothing, goggles, gloves) and provide plenty of ventilation.
- Immediately clean spills.
- Most solvents are flammable and/or toxic and must be handled with extreme care. Do not use near open flame, sparks, or electrical motors.

RECOMMENDATIONS

- Do not power-wash windows or use a garden hose; this can cause seal failure and allow water to enter the structure.
- When cleaning exterior, multi-story windows, begin with the upper story and work down.
- Avoid using metal tools, razor blades, or other sharp objects and abrasive cleaners. They can damage window surfaces, scratch glass and remove exterior glass coatings.
- Do not allow aggressive cleaners to come into contact with metal clad or wood surfaces. Immediately rinse and dry.
- Do not allow cleaners to puddle or collect at glass edges near glazing materials.
- Avoid cleaning in direct sunlight or in temperatures too hot or too cold.
- Avoid excessive rubbing and over-cleaning.
- Do not scour.
- Clean and rinse one area at a time.
- Clean twice a year (monthly in coastal areas) or when dirty.
- After-market tints and films are not recommended, as they may cause damage to the glass and/or sealant.

NEEDED MATERIALS & TOOLS

MATERIALS

- Baby shampoo or mild soap, or vinegar, and water
- Several clean, soft, non-abrasive, absorbent lint-free dry cloths (cleaning)
- High quality, non-abrasive car wax (for hardware)
- Appropriate finishing supplies and solvents
- Commercial glass cleaning products or solvents
- Non-abrasive paste cleaner and baking soda (for copper cladding)
- Plastic wrap (for label removal)
- Plenty of rags (for finishing or painting)
- Wood filler
- High quality sealant (100% polyurethane if painted and 100% silicone if left exposed)

TOOLS

- Soft bristle brush
- Spray bottle
- Sponge
- Plastic putty knife (for paint or label removal)
- Metal putty knife or paint scraper
- Brushes (small and large)
- Wire brush
- Sanding block with medium and fine sandpaper
- Tack cloth
- Drop cloth
- Thin wire

BASIC INSPECTIONS & MAINTENANCE

INSECT SCREENS

1. Inspect screens for:
 - Cuts, scratches, or holes
 - Looseness
2. Replace or repair damaged screens. Contact a local supplier for repair or replacement information.

Note! Screens may not be covered under manufacturer's warranty. To be sure, ask your supplier or distributor.

Cleaning

1. Remove screen and place screen into tub or shower if indoors; on lawn or hard surface if outdoors (avoid exposure to dirt).
2. Gently spray with water and brush lightly with soft bristle brush until clean.

For stubborn dirt,

1. Gently scrub with soft bristle brush with mild soap and water.
2. Rinse clean.
3. Reinstall screen.

Phantom Screens®



Phantom Screens mount to the inside of the window and can be retracted when not in use. The screen operates by pulling it down over the window through tracks mounted in the side jambs.

Phantom Screens require the same type of care and maintenance that conventional screens do. However, because of the nature of the product, they do require some additional special care.

Use the following guidelines with Phantom Screens:

- Screens should be retracted into protective storage housing when not in use.
- Spring loaded systems may retract suddenly.
- Do not push the mesh to release the magnet or latch.

- A safety feature releases the side bar if the mesh is lightly bumped.
- When rolling the screen into the housing, ensure the mesh rolls evenly.
- Retracting the product with creases in the screen can cause wrinkles.
- Ensure tracks are kept free of dirt and debris, which may cause the screen to perform poorly.
- Clean the mesh fabric, housing tracks and slide bar with mild soap and water and a soft brush. Do not use chemicals or pressure washers. Allow the mesh to dry before rolling it back up into the housing.

SASH/PANEL INSPECTION

- Inspect sash or patio door panel annually (monthly for coastal areas).
- Inspect stiles and rails for damage (cracks or splits in wood surfaces, dents or scratches to cladding).
- Immediately repair scratches or cracks in painted or finished surfaces.

Note! For scratches on aluminum clad surfaces, call us or your supplier for a paint touch-up kit. For damage other than scratches, call a service technician for assistance.

- Check glass for cracks. If cracked, call your local glass supplier for replacement.
- For insulating glass units, look for moisture or fogging between glass panes (most likely to occur on cold mornings). This may be an indication of seal failure. Call us for recommendations.

WEEP SYSTEM

Some windows and patio doors are designed with weep systems. These systems channel water out of the window or door and away from the structure. When water does not drain properly to the exterior, it could drain to the interior and cause extensive damage.

For products with weep holes, clean as follows:

1. Regularly clean sill track with vacuum, or wipe thoroughly with damp cloth.
2. Pour small amount of water (1 cup) into interior sill track. The system is clear if water drains through exterior weep holes. If not, carefully clear with a thin wire. Repeat until water runs clear to the exterior. If not successful, call a service technician.

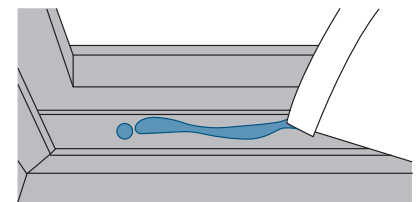

BASIC INSPECTIONS & MAINTENANCE – CONTINUED

WEATHERSTRIP

Inspecting and maintaining weatherstrip can help avoid costly structural damage from water leakage and energy loss due to air and/or water infiltration. Replace weatherstrip, that is missing, torn, cracked, brittle, discolored, gummy, or that has no “bounce back” when pressed down. Call us for replacement instructions.

Precautions

- Solvents such as mineral spirits or petroleum-based products may damage or dissolve weatherstrip.
- When using alcohol, always test small area first to avoid product damage.
- Do not allow solvents or silicone to touch wood or clad surfaces around weatherstrip.
- Do not use abrasives, sanders, or anything sharp near weatherstrip.

Light Cleaning

1. Clean with damp cloth or mild soap and water.
2. Rinse and dry thoroughly.
3. Repeat if necessary.

Non Water-Soluble Cleaning

Clean with denatured alcohol on soft cloth. Test on inconspicuous area first. If denatured alcohol doesn't work:

1. Clean with small amount of lacquer thinner on soft cloth. Follow all instructions.
2. Repeat if necessary.
3. Clean with mild soap and water, then rinse. If unsuccessful, consider replacing weatherstrip.

Weatherstrip Repair

If weatherstrip is loose or falling out of the kerf:

1. Carefully remove weatherstrip.
2. Apply thin bead of silicone sealant into kerf.
3. Reinstall weatherstrip.
4. Hold in place with tape for 24 hours.
5. Carefully remove tape.

EXTERIOR SIDING JOINT

A proper seal of the joint between the window and the exterior surface of the structure will provide a proper shield from the elements and will keep water and/or air from leaking into the home.

1. Inspect sealant in the joint for:
 - Cracks
 - Voids
 - Deteriorating areas (e.g. loss of adhesion)
2. Repair damaged sealant with a best quality sealant.

Note! Do not apply sealant to areas where installer or contractor did not originally seal. Seek professional advice from an installer or contractor if unsure.

When repairing a sealant joint, 100% silicone sealant is the most durable, but it cannot be painted. Use 100% polyurethane sealant if painted. Follow sealant manufacturer's instructions for proper application.

GUTTERS & OVERHANGS

Gutters and overhangs protect windows from excess exposure to water. Clear at least once a year.

CLEANING GLASS

Some window sashes may be removed (horizontal slider), tilted in (tilt single and double-hung), or opened (casements without egress hinges) for easier access to the exterior surface. Custom and premium wood products are available with optional Neat® glass. Neat glass stays cleaner longer with less maintenance and needs no manual activation. Visit www.cardinalcorp.com for more information.

GENERAL CLEANING

Prepare cleaning solution (1 tsp baby shampoo to one gallon of water or 1 1/2 cups vinegar to one gallon of water).

1. Rinse surface with clean water from top to bottom.
2. Clean with mild soap and water and sponge or soft brush with uniform pressure horizontally, then vertically.
3. Promptly rinse thoroughly with clean water (sponging while rinsing may be helpful; do not allow cleaning solution to dry on the surface or collect and puddle).
4. Wipe dry with lint-free dry cloth.
5. If necessary, repeat steps above until clean.
6. Dry window frame and sill with separate cloth.

LABEL REMOVAL

Slowly peel from one corner. If label tears or sticks, moisten with soapy water and gently scrape with plastic putty knife. Stubborn labels can be soaked with soapy water and covered overnight with plastic wrap. Gently remove with plastic putty knife.

PAINT REMOVAL

1. Soak dried latex paint drips with warm water and baby shampoo solution.
2. Wipe with damp cloth or sponge.
If needed,
3. Scrape gently with plastic putty knife. Repeat soak and scrape.
4. Repeat if necessary.

Note! For oil-based paint drips, consult a paint professional.

CLEANING GLASS – CONTINUED

STUBBORN STAIN REMOVAL

Commercial glass cleaning products may be necessary.

- Apply small amount directly to the stain. Avoid spilling or dripping down the glass.
- Some persistent stains may need higher strength cleaning solutions that contain active ingredient chemicals such as toluene, xylene, mineral spirits or naphtha. Special care must be taken when using these types of cleaners.
- For oil and grease: try baking soda and water or washing soda and water.

MORE INFORMATION ON GLASS CLEANING

- The Glass Association of North America (GANA): www.glasswebsite.com
- Cardinal Glass Industries: www.cardinalcorp.com

Note on Websites! Website content is subject to change and should be used for informational purposes only. JELD-WEN is not responsible for third-party information.

HARDWARE CLEANING & LUBRICATION

Cleaning and lubrication help to maintain and restore smooth operation to movable parts of windows and patio doors and, in most cases, offer corrosion protection. Always thoroughly clean hardware before lubricating.

Maintain hardware any time windows are not opening or closing properly or at least bi-annually (monthly for coastal areas) for:

- Clean dirt/debris
- Tighten loose screws
- Replace damaged hardware

Use caution with silicone-based sprays. Apply only in small amounts and do not overspray. Wipe off excess lubricant to avoid staining and/or damage to other window or patio door parts. Silicone may cause some hard plastic parts to become brittle and cause problems with finishing or refinishing wood surfaces.

PRECAUTIONS

The following substances may damage protective hardware finishes. Do not use:

- Vinegar-based cleaners
- Citrus-based cleaners (lemon, etc.)
- Paint removers
- Window cleaners
- Brick/siding washes
- Any other industrial or abrasive cleaners

HARDWARE TYPES

Metal hardware offers functionality, aesthetic appeal and resistance to corrosion, but is not totally corrosion proof. Replace corroded hardware.

Plastic hardware offers high resistance to the elements; however, over time, can deteriorate from ultraviolet light, heat, cold, and chemical exposure.

Brass hardware has a special protective film to reduce/eliminate polishing and requires special care.

HARDWARE CLEANING

General Cleaning

1. Remove hardware for easier cleaning.
2. Use mild soap and water on a soft cloth or sponge; rinse and wipe dry. For stubborn dirt, use a soft bristle brush to gently scrub.
3. Apply several coats of high quality, non-abrasive car wax.
4. Reinstall hardware.

For tough-to-clean brass hardware:

- a. Soak overnight in lacquer thinner or paint reducer.
 - b. Dry completely.
 - c. Apply brass polish to dry hardware (follow instructions on manufacturer's label).
 - d. After polishing, apply several coats of high quality, non-abrasive car wax.
 - e. Prolong finish with follow-up wax applications.
3. Reinstall hardware.

Tarnish Cleaning (Brass Hardware)

This section does not apply to brass-plated hardware. The following cleaning and polishing procedure is recommended by a brass hardware company.

1. Carefully remove hardware.
2. Gently clean with extra fine steel wool (No. 0000) soaked in light oil or mild soapy water.

Heavy Cleaning

Solvents, abrasives, and other cleaners could cause damage to protective coatings on hardware. If the general cleaning procedure is not sufficient, call us for recommendations.

HARDWARE LUBRICATION

Different hardware parts need different types of lubricants.

Suggested Lubricant Types

White or Lithium Grease:
Protects metal surfaces against corrosion, reduces friction and wear on moving parts, and is an excellent multi-purpose lubricant.

Light Oil (such as 3-in-One®):
Use for sliding or rotating joints.

Graphite (spray black carbon powder):
Use for door lock key ways and hinges.
Note! Use care when applying graphite to prevent possible staining of parts.

Spray Silicone:
Use for slider tracks, jamb liners, and weatherstrip.
Note! Do not spray directly onto hardware surfaces. Spray onto clean cloth to apply.

Plastic Hardware

Most hard plastic hardware parts (e.g. sash retainer latches) require periodic cleaning for smooth operation and do not require lubrication.

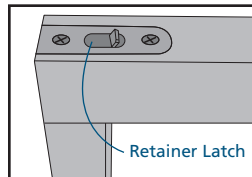

Butt Hinges

Note! Butt hinges are located on swinging patio doors and some window styles. Lubricate hinges with light oil (3-In-One® oil or equivalent) annually or when noisy.

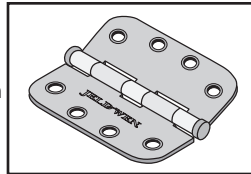

Casement/Awning Hardware

Note! New operators and hinges are already greased and oiled and should not need lubrication. Periodically lubricate operator gear mechanisms with white or lithium grease.

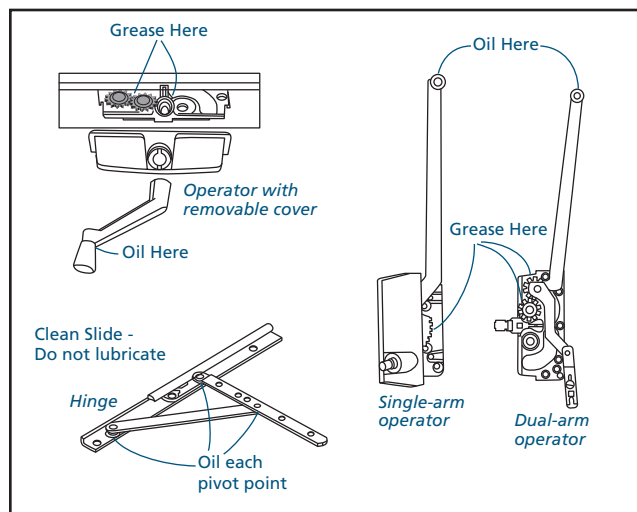

There are two types of operators with gear mechanisms:

- Removable cover
- Non-removable cover with the gears reachable through the back

Casement/Awning Hardware – Continued

For operators with removable covers:

Note! Some handle styles don't have screws and will just pull off.

1. Remove set screw on crank handle with small screwdriver or Allen wrench; remove handle.
2. Gently remove plastic cover (lift from the base).
3. Apply grease to gears and oil to joints.

For operators with non-removable covers:

1. Use a small mirror for a better view of the gears.
2. Apply grease/oil through back side of operator.

Casement/Awning Rotating Joints

Light oil provides lubrication for rotating joints such as hinge pivots. Spray lubricants or graphite are acceptable, but need frequent application.

1. Open window for access to joints.
2. Oil as shown.

Slider Tracks & Jamb Liners

Slider tracks or jamb liners can become dirty and difficult to operate. Keep clean and lubricate as follows:

1. Remove sash(es).
2. Vacuum track or wipe with a soft cloth.
3. Apply spray silicone to dry, soft cloth. Wipe onto track, jamb liner and/or weatherstrip. Do not apply silicone to wood surfaces or pile (fuzzy) weatherstrip.
4. Reinstall sash(es) and check operation.

Patio Door Rollers & Multi-Point Locks

Removing patio door panels can be dangerous and should be performed by service personnel or at least with additional help.

1. Remove door panel.
2. Tip door panel for access to rollers on the bottom.
3. Lubricate rollers where the shaft goes through the middle of the wheels with light oil.

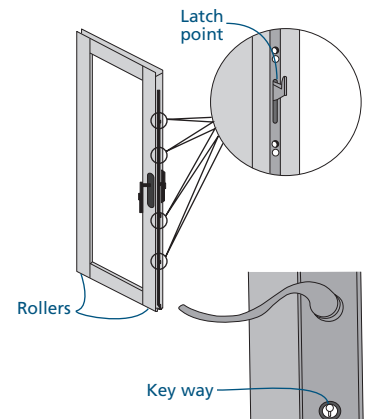

1. Lightly oil multi-point lock at each latch point.
2. Spray keyway lock with graphite lubricant.

CLEANING WOOD SURFACES & CLADDING

Wood window care includes proper finishing and maintenance of wood and cleaning and caring for metal clad surfaces. Bi-annual inspections are sufficient for most areas; however, coastal areas require monthly inspections because of moisture and salt in the air.

EXPOSED WOOD SURFACES

Clean exposed wood surfaces with mild soap and water. For stubborn residue or mildew, consider lightly sanding and refinishing, or contact a paint professional for recommendations.

Refinish cracks or voids immediately.

COPPER CLADDING

JELD-WEN copper clad products and components will naturally change color and appearance over time due to exposure to the environment. Depending upon the products' specific exposure, differences in appearance may occur in the same structure. Repair or replacement of products may also result in variations between original and replacement parts. JELD-WEN is not responsible for any variations in appearance of copper parts.

Wear cotton gloves during installation or servicing to avoid fingerprints on copper surface. If fingerprints do occur and the following recommendations for cleaning do not remove them, call us for assistance.

Maintenance & Cleaning

To maintain an aged look, no maintenance is required except for occasional cleaning of surface debris with mild soap and water. For heavier cleaning, follow the same cleaning instructions for aluminum cladding. Do not use any solvents or cleaners that contain ammonia, salts or oxides.

Oxidation Removal

For a shiny, non-oxidized copper appearance, try removing the oxidation with a baking soda/water solution. A non-abrasive paste cleaner may also work. Always test in an inconspicuous area first, and read the manufacturer's label for instructions.

ALUMINUM CLADDING

Aluminum cladding offers durability and excellent resistance against cracking, blistering, and flaking under normal use. When properly maintained, aluminum clad products will remain attractive for many years. Aluminum cladding usually does not require painting or finishing; however, we offer special touch-up paints to repair scratches. Call us for more information.

Painted clad surfaces exposed to sunlight are subject to chalking which may cause color-fading. This is a natural process that occurs over time, even with proper maintenance. If painted surfaces become very chalked or faded, repainting may be an option.

Certain chalking or fading and damage to exterior cladding from acid rain, salt air, or other corrosive elements may not be covered under the manufacturer's warranty.

ALUMINUM CLADDING – CONTINUED

Moderate to Heavy Non Water-Soluble Cleaning

Some solvents are acceptable for removing heavy soils (e.g. oil, grease, sealants, dried concrete stains, tar, rust and graffiti). See the following Solvent Recommendations. After using solvents, clean area with mild soap and water to remove traces of remaining solvent.

Note! Do not use solvent on painted surfaces other than metal cladding or damage may result.

Solvent Recommendations For Aluminum Cladding

Caution: Do not allow petroleum-based products to come in contact with hardware and weatherstrip. Do not use acetone and paint removers on coated aluminum clad surfaces. They may remove coatings.

These solvents may be used to clean non water-soluble debris from coated aluminum clad surfaces. **Use only in small, inconspicuous areas first.**

Alcohols:

Try these least strong solvents first for non water-soluble debris.

- Denatured alcohol (ethanol)
- Isopropyl (rubbing alcohol)
- Methanol (wood alcohol)

Petroleum solvents and turpentine:

Especially helpful in removing grease, sealants, or some caulking compounds.

- VM&P naphtha
- Mineral spirits
- Kerosene
- Turpentine (wood or gum spirits)

Ketones, esters and lacquer thinner:

Use with extreme caution. Limit contact to one minute.

- Lacquer thinner
- Methyl ethyl ketone (MEK)

Chemical solutions:

Especially helpful in removing rust and masonry grout or concrete stains. Limit contact to five minutes. Thoroughly rinse with water. Acid solutions are corrosive. Mix one part to ten parts water.

- Sodium hypochlorite solution (laundry bleach)
- Acetic acid (vinegar)
- Hydrochloric acid (muriatic acid)

For more information, contact a paint professional.

FINISHING & REFINISHING

This is a guideline for painting and finishing wood surfaces on windows and patio doors. Consult a paint professional for specific “how-to” instructions and additional materials.

During manufacturing of primed wood products, a waterborne, modified acrylic primer is applied for good paint film adhesion and some wood protection during shipping, handling and installation.

If storing before installation, place in a dry, well-ventilated, protected area. Do not expose to rain, extreme humidity and/or heat. If finishing more than 20 days after delivery (after 20 days, primers rapidly lose the ability of optimal adhesion to the top coat), clean with mild soap and water, soft bristle

brush, and rinse and dry thoroughly. Lightly sand the surface and remove all dust with a vacuum or tack cloth. Apply an additional coat of primer designed for use with the final top coat.

FINISHING AURALAST® WOOD

AuraLast wood is not finished any differently than any other wood, with one exception: JELD-WEN does not recommend the use of water-based dye stains. AuraLast wood is water repellent, and as a result, the dye cannot penetrate the wood. Water-based pigment stains, however, will produce acceptable results. AuraLast accepts any high quality paint.

1 SELECT MATERIALS & FINISHING PRODUCTS

When preparing to finish or refinish wood products, consider the tools and materials you will need for the entire project. Listed below are some common painting/finishing product types to consider. Specific tools or materials may vary.

Note! Areas with extreme climates and corrosive environments (coastal and humid areas) require specially designed products that offer extra protection. Avoid using shellac, lacquer or oil and wiping varnish finishes on exterior surfaces. They do not meet the resistance characteristics needed for window and patio door products.

Special Note on Veneered Parts

Many interior surfaces are not solid wood, but covered with a veneer, or thin piece of wood. Veneered parts are engineered for enhanced strength, warp-resistance and surface consistency when accepting paint or stain. Many times it will not be obvious if a part is veneered or not. Because of the delicate nature of veneer, all parts of the wood window should be treated as though they are veneered. Finishing veneered products is the same as finishing solid wood except it is possible to sand through the veneer. Components receive a factory finish and should not require further sanding. If light sanding is necessary, use closed grit 240 or finer.

FINISHING PRODUCTS

There are many different options for painting or staining. Visit a local paint store for recommendations on types, colors, sheens and application methods. Many paint stores offer color sample cards you may take home.

Note! Clear finishes are not recommended for exterior surfaces because of the need for extensive annual inspections and maintenance to repair/refinish. Clear finish application is at the owner's own risk and may result in denial of warranty claims.

Finishing Product Recommendations

Primers:

- Primers seal wood surfaces and without them, a painted wood surface may look flat in porous areas.
- Some paint manufacturers offer low temperature primers that may still be applied below 50°.
- Select primer appropriate for the top coat.

Paints:

- Use paint designed for exterior/interior applications.
- Avoid dark-colored paints. They absorb heat from the sun and may crack more easily, increasing maintenance.

Stains & clear finishes:

- Stains add and enhance color.
- Use only solid color stains on exterior surfaces because their high concentration of pigments protects wood against sun damage. The natural wood color and grain is obstructed, but the wood texture is retained.
- Select a clear finish with resistance to water, wear, heat, solvents and chemicals. Without these characteristics, the finished product may deteriorate, compromising its integrity.
- Use a clear topcoat containing UV absorbers. Exterior finishing products provide extra protection and durability for interior surfaces still exposed to sunlight.

2 PREPARE TO FINISH

1. Observe weather conditions.
 - Do not attempt painting/finishing in wet weather or any extreme environmental conditions.
 - The normal temperature range recommended by paint manufacturers is 50°-85°. After finish application, the temperature should not drop below the minimum for at least four hours. Some products have a wider temperature range.
 - The relative humidity should be below 85%. Relative humidity can be measured with a hygrometer, found at a local hardware store or home center.
 - Paint/finish in a location that is well lit, but not in direct sunlight and allows plenty of ventilation.
2. Check wood moisture content.
Do not begin project if wood moisture content exceeds 16%. Check using a hand-held moisture meter (should be available at local hardware, home improvement or paint store) or gently sand the surface with fine grit sandpaper. Fine, fluffy or powder-like dust means the wood is dry, but if the sandpaper fills with wood residue, the wood is too wet.
3. Prepare enough material to complete the project.

PREPARE DOUBLE-HUNG SASH

On double-hung windows, the moving sash stile edges that come in contact with the jamb liners need to be sealed, not painted. The sealer should adequately seal the sash and not cause operational problems.

Minimize the film thickness on the sash edge. Sash stile edges that have weatherstrip and do not come in contact with the side jamb or jamb liner may be painted the same as the rest of the window.

High-quality sealer products include Watco® Exterior Wood Finish, MinWax® ClearShield™, or other equivalent product.

3 PREPARE WOOD SURFACE

Proper wood surface preparation is essential before finishing. Clear coat refinishing may vary depending on the type of finish previously used. Mildew stains must be removed before finishing or refinishing. Seek professional help if unsure. This section covers wood preparation for exterior and interior, new and previously finished wood surfaces.

1. Remove (double-hung, single-hung, slider) or open (casement, awning, basement) sash before finishing. Allow the sash to completely dry before reinstalling or closing.
2. Remove or protect hardware and other non-wood items such as gaskets, hinges, locks, jamb liners and weatherstrip from finishing and/or damage. Do not allow finishing products to come into contact with these parts.
3. Remove all loose, peeling, flaking, or scaling paint without gouging the wood surface.
4. Fill all holes, gouges, scratches, dents (see following tip), or other imperfections with wood putty.

Note! Water-based putty can react with screws, nails and staples and cause rust stains on the wood surface.

PREPARE PHANTOM SCREEN®

Non-Removable Screen Tracks: Casement & Awning Windows

1. Open window.
2. Remove the housing cover by tilting the cover upward to detach from the housing. Once cover detaches, carefully pull away).
3. Reattach housing cover once stain is thoroughly dried.

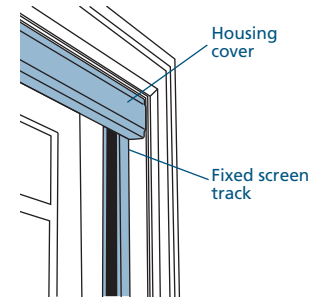

Removable Screen Tracks: Double-Hung & Horizontal Gliding Windows

1. Grip lower end of the screen track.
2. Applying even, steady pressure, carefully pull the track until it releases from its holding clip.
3. Continue pulling bottom of track until it is 6 inches away from the stile.
4. Tilt track toward you and pull down and away from housing cover.
5. Repeat steps 1-4 to remove remaining track.

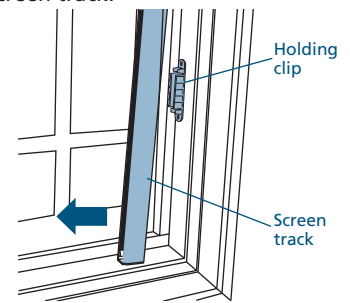

- TIP:** Use the following method to steam away dents (if wood fibers are still intact):
- a. Place a drop or two of water on the dent.
 - b. Let soak.
 - c. Cover with a wet cloth.
 - d. Heat with tip of a warm iron.
 - e. Let dry thoroughly.

3 PREPARE WOOD SURFACE – CONTINUED

5. Sand smooth (with the grain) any surface roughness with a cork, felt, or rubber-backed sanding block to avoid uneven depressions in the wood. Sand with the folded edge of the sandpaper facing the direction of travel (an open edge is more likely to catch under a sliver of wood and lift it).
6. Apply sufficient sealant/caulk to joints where wood parts come together to prevent moisture access (100% silicone if left exposed, 100% polyurethane if painted).
7. Thoroughly remove dust from wood surface (finish will not adhere properly to unclean surface) with a vacuum, tack cloth or damp rag. If necessary, use paint thinner to clean oil, wax or grease. Do not use compressed air because moisture in air could cause water spotting.

4 FINISH WINDOW OR PATIO DOOR

Apply finish applications in multiple light coats. Apply at least two top coats of paint over primer or high grade clear coat over stain. Apply material evenly, and follow label instructions for time between coats. Consult a local paint professional when staining pine and other soft woods for methods to minimize uneven stain appearance, or for any other finishing problems.

Note! Do not finish hardware or other non-wood parts such as hinges, jamb liners or locks. If finishing products do come into contact with these parts, immediately wipe with a clean rag.

1. IF painting, apply primer (two coats for damaged areas) to all exposed wood surfaces (including top and bottom of sash) and let dry thoroughly.
IF staining, apply stain as desired. More stain will result in a darker finish, less stain in a lighter finish.
2. After primer/stain is dry, apply top coats to all exposed wood surfaces.
3. After the last top coat is completely dry, reinstall hardware, weatherstrip, etc. Operational problems may occur if the top coat is not thoroughly dry.
4. Reinstall sash or panel.

Staining Phantom Screens®

1. Stain both exterior and interior of left and right tracks.
2. Stain housing cover located at the top of your window.
3. Stain handle being careful not to stain the mesh screen material.
4. Reassemble components in reverse order when staining is complete and thoroughly dried.

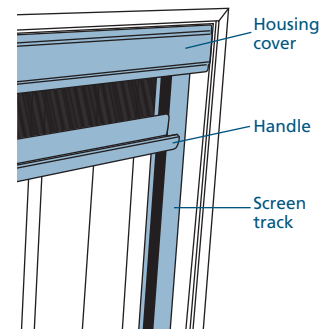

GLOSSARY

Casement

A window with a sash that opens from the side like a door.

Clad

A metal protective shell on the exterior of some wood windows and patio doors. Usually aluminum or copper.

Double-Hung

A window with an upper and lower sash that slide vertically past each other.

Egress Hinge

A hinge used in conjunction with certain casement windows to allow a wider opening to meet emergency exit requirements.

Frame

The assembly of structural members (head, sill and jambs) used to fasten the window/patio door to the structure.

Insulated Glass Unit

A sealed assembly of two or more panes of glass separated by a spacer.

Jamb Liner

A removable balance system that fits into the side jamb.

Kerf

A groove that often holds weatherstrip.

Keyway

The slot in the lock where the key is inserted.

Lite

A framed opening in the glass within a sash or door panel; frequently used in reference to glass divided by a grid into multiple smaller openings.

Rail

The horizontal piece of a sash or panel.

Sash/Panel

An assembly comprised of stiles (vertical pieces), rails (horizontal pieces) and the window or patio door's glass.

Seal Failure

The airtight seal between two panes of an insulating glass unit has broken and is usually discovered when excess moisture fogs the inside of the glass panes.

Side Jamb

The vertical frame member on either side of the window or patio door.

Sill

The bottom horizontal frame member of a window.

Sill Track

The track on the sill of a sliding/gliding window or patio door that guides the sash as it opens and closes.

Slider

A window with one or more sashes that slide horizontally.

Stile

The vertical piece of a sash or panel.

Weatherstrip

A strip of material that covers the joint between two separate parts of a window or patio door and is used to prevent rain, snow and cold air from entering.

Weep Hole

The visible exit or entry part of a water drainage system used to drain water out of a window unit.

INSPECTION CHECKLIST

INSPECTION DATE ____/____/____

EXTERIOR	NOTES
<ul style="list-style-type: none"> • Paint/Cladding <ul style="list-style-type: none"> <input type="checkbox"/> Dirty <input type="checkbox"/> Cracks, scratches, blisters, other damage 	
<ul style="list-style-type: none"> • Sealant Joint <ul style="list-style-type: none"> <input type="checkbox"/> Cracks, voids, other damage <input type="checkbox"/> Deterioration, loss of adhesion 	
<ul style="list-style-type: none"> • Glass <ul style="list-style-type: none"> <input type="checkbox"/> Dirty <input type="checkbox"/> Scratched, cracked, other damage 	
<ul style="list-style-type: none"> • Weatherstrip <ul style="list-style-type: none"> <input type="checkbox"/> Missing or loose <input type="checkbox"/> Tears, cracks, other damage <input type="checkbox"/> Brittle, gummy, discolored <input type="checkbox"/> No "bounce back" 	
<ul style="list-style-type: none"> • Insect Screen <ul style="list-style-type: none"> <input type="checkbox"/> Dirty <input type="checkbox"/> Missing or loose <input type="checkbox"/> Mesh damaged or loose 	
<ul style="list-style-type: none"> • Gutters <ul style="list-style-type: none"> <input type="checkbox"/> Dirty <input type="checkbox"/> Damaged <input type="checkbox"/> Missing 	
INTERIOR	
<ul style="list-style-type: none"> • Paint or Finish <ul style="list-style-type: none"> <input type="checkbox"/> Dirty <input type="checkbox"/> Scratched, cracked, other damage 	
<ul style="list-style-type: none"> • Glass <ul style="list-style-type: none"> <input type="checkbox"/> Dirty <input type="checkbox"/> Moisture between Panes (insulating glass only) 	
<ul style="list-style-type: none"> • All Product Hardware <ul style="list-style-type: none"> <input type="checkbox"/> Dirty or damaged <input type="checkbox"/> Discolored or tarnished <input type="checkbox"/> Problems with sash locks 	
<ul style="list-style-type: none"> Casement/Awning Windows <ul style="list-style-type: none"> <input type="checkbox"/> Operators working properly <input type="checkbox"/> Operators need lubrication 	
<ul style="list-style-type: none"> Double/Single-Hung Windows <ul style="list-style-type: none"> <input type="checkbox"/> Jamb liners damaged <input type="checkbox"/> Sash balances fail to hold properly <input type="checkbox"/> Problems with sash tilt latches <input type="checkbox"/> Problems with cam pivots 	
<ul style="list-style-type: none"> Sliding/Gliding Windows <ul style="list-style-type: none"> <input type="checkbox"/> Track dirty 	
<ul style="list-style-type: none"> Patio doors <ul style="list-style-type: none"> <input type="checkbox"/> Track dirty <input type="checkbox"/> Problems with rollers <input type="checkbox"/> Problems with locks <input type="checkbox"/> Locks or hinges need lubrication 	