



Caring for your vinyl windows and patio doors will save time and money. It is necessary to take some time every year to clean and inspect your vinyl windows and patio doors for cracks and damage. Proper maintenance requires periodic tasks to maintain long life, smooth operation, and warranty coverage. Regular inspections and minor maintenance are the best ways to keep these products in good condition.

Do-It-Yourself

Technician



## INTRODUCTION

This guide provides important information that will help to keep vinyl windows and patio doors looking beautiful and operating smoothly for many years. Vinyl products contain ultraviolet (UV) inhibitors designed to reduce sun damage. Vinyl is manufactured to be low maintenance and long lasting without the need for painting or finishing.

## TABLE OF CONTENTS

Precautions and Safety . . . . .	2
Needed Materials & Tools . . . . .	2
Basic Inspections & Maintenance . . . . .	2
Cleaning Glass & Vinyl Surfaces . . . . .	4
Hardware Cleaning & Lubrication . . . . .	5
Glossary . . . . .	7
Inspection Checklist . . . . .	8

## CONTACT US

- For questions, feel free to contact us by phone or email:
- Email: [customerserviceagents@jeld-wen.com](mailto:customerserviceagents@jeld-wen.com)
  - Phone: 1-(800)-JELD-WEN/1-(800)-535-3936

## WINDOW & PATIO DOOR PARTS

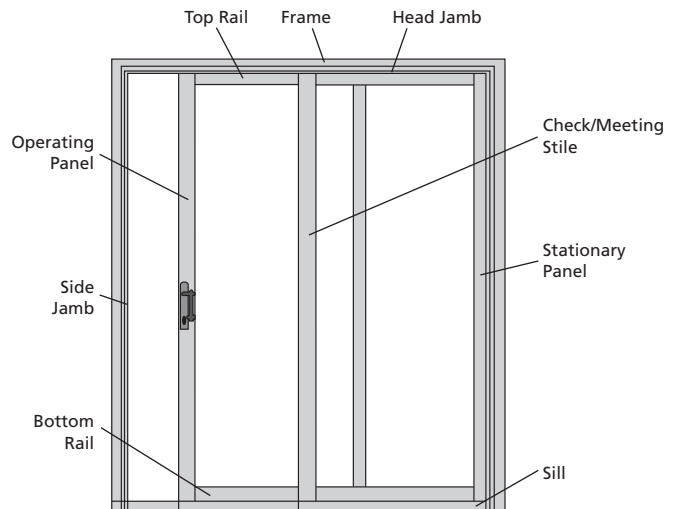
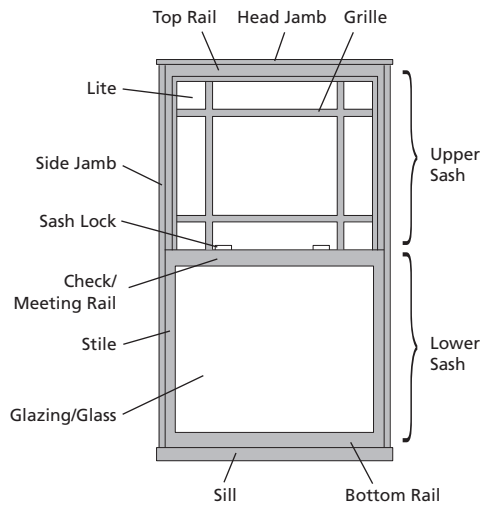

The advice offered herein can be done by a homeowner with some mechanical aptitude. If you are unsure, it is recommended that you hire a trained service provider such as a competent and licensed construction contractor or building professional. JELD-WEN disclaims any and all liability associated with the use and/or provision of these instructions. Any reliance upon the information or advice is at the risk of the party so relying. The information contained herein may be changed from time to time without notification.

## PRECAUTIONS, SAFETY & CLEANING RECOMMENDATIONS

### PRECAUTIONS & SAFETY

- Window insect screens are not security devices and will not prevent a child or anyone from falling through.
- Never mix cleaners or solvents. This may be dangerous as well as ineffective.
- Use help when working with a large window sash or patio door panel to avoid injury.
- Use proper/safe equipment and precautions when cleaning and servicing the exterior side of windows above ground level.
- If using commercial cleaning or finishing products or solvents, carefully read and follow safety instructions, warnings, cautions and disposal instructions on manufacturer's labels. Wear appropriate safety gear (e.g. clothing, goggles, gloves) and provide plenty of ventilation.
- Immediately clean spills.
- Most solvents are flammable and/or toxic and must be handled with extreme care. Do not use near open flame, sparks, or electrical motors.

### RECOMMENDATIONS

- Do not power-wash windows or use a garden hose; this can cause seal failure and allow water to enter the structure.
- When cleaning exterior, multi-story windows, begin with the upper story and work down.
- Avoid using metal tools, razor blades, or other sharp objects and abrasive cleaners. They can damage window surfaces, scratch glass and remove exterior glass coatings.
- Aggressive cleaners or solvents can damage vinyl surfaces and may cause yellowing. Immediately rinse and dry.
- Do not allow cleaners to puddle or collect at glass edges near glazing materials.
- Avoid cleaning in direct sunlight or in temperatures too hot or too cold.
- Avoid excessive rubbing and over-cleaning.
- Do not scour.
- Clean and rinse one area at a time.
- Clean twice a year (monthly in coastal areas) or when dirty.
- After-market tints and films are not recommended, as they may cause damage to the glass and/or sealant.

## NEEDED MATERIALS & TOOLS

- Baby shampoo or mild soap and water or vinegar and water
- Several clean, soft, non-abrasive, absorbent Chamois or lint-free dry cloths
- Soft bristle brush
- Spray bottle
- Vacuum cleaner
- Sponge
- Appropriate solvent (for hardware only)
- Commercial glass cleaning products or solvents (for stubborn stains)
- Plastic putty knife (for paint or label removal)
- Plastic wrap (for label removal)
- Spray silicone

## BASIC INSPECTIONS & MAINTENANCE

### INSECT SCREENS

1. Inspect for the following:
  - Cuts, scratches, or holes
  - Looseness; tighten excessively loose screws.
2. Maintain:
  - Lightly lubricate tracks with silicon spray.
  - During freezing, optional retractable screens should be fully retracted.
  - Clean tracks with a vacuum.
3. Replace or repair damaged screens; if replacement is necessary, contact a local supplier for repair or replacement information.

Your local hardware or home improvement store is a good source for supplies and information on screen repair.

#### Cleaning

1. Remove screen and place screen into tub or shower if indoors; on lawn or hard surface if outdoors (avoid exposure to dirt). For retractable screens, clean in place.
2. Gently spray with water and brush lightly with soft bristle brush until clean (use gentle spray nozzle setting).

For stubborn dirt,

1. Gently scrub with soft bristle brush with mild soap and water.
2. Rinse clean.
3. Reinstall screen when dry.

#### Tips for best operation of optional retractable patio door screens

- Use caution when moving heavy objects over tracks.
- If additional magnetic force is required, adjust strike plate so that flat side faces magnets.
- Do not apply excessive pressure to the screen handle; check for obstructions or misaligned tracks.
- If screen binds, try slightly loosening track screws, and/or add a lubricant such as silicon spray.

**Note!** Screens may not be covered under manufacturer's warranty. To be sure, ask your supplier or distributor.

## BASIC INSPECTIONS & MAINTENANCE – CONTINUED

### SASH/PANEL INSPECTION

Inspect sash or patio door panel annually (monthly for coastal areas). If the window has a removable sash, it may be helpful to remove it before inspection.

- Inspect stiles and rails for damage (cracks or splits in vinyl surfaces).
- Check glass for cracks. If cracked, call your local glass supplier for replacement.
- For insulating glass units, look for moisture or fogging between glass panes (most likely to occur on cold mornings). This may be an indication of seal failure. Call us for recommendations.

### WEATHERSTRIP

Inspecting and maintaining weatherstrip can help avoid costly structural damage from water leakage and energy loss due to air and/or water infiltration. Replace weatherstrip that is missing, torn, cracked, brittle, discolored, gummy, or that has no “bounce back” when pressed down. Call us for replacement instructions.

#### Precautions

- We recommend denatured alcohol for non water-soluble cleaning. Lacquer thinner may be used in small amounts, but only as directed. Thoroughly rinse any vinyl surfaces that come into contact with lacquer thinner. Other solvents such as mineral spirits or petroleum-based products may damage or dissolve weatherstrip.
- When using alcohol, always test small area first to avoid product damage.
- Do not use anything sharp near weatherstrip.

#### Light Cleaning

1. Clean with damp cloth or mild soap and water.
2. Rinse and dry thoroughly.
3. Repeat if necessary.

#### Non Water-Soluble Cleaning

Clean with denatured alcohol on soft cloth. If denatured alcohol doesn't work:

1. Clean with small amount lacquer thinner on soft cloth.
2. Repeat if necessary.
3. Clean with mild soap and water, then rinse. If unsuccessful, consider replacing weatherstrip.

#### Repair

If weatherstrip is loose or falling out of the kerf:

1. Carefully remove weatherstrip.
2. Apply thin bead of silicone sealant into kerf.
3. Reinstall weatherstrip.
4. Hold in place with tape for 24 hours.
5. Carefully remove tape.

### GUTTERS & OVERHANGS

Gutters and overhangs protect windows and patio doors from excess water exposure. Clear at least once per year.

### WEEP SYSTEM

Vinyl windows and patio doors are not subject to moisture damage; however, damage could develop in the structure around the unit if water does not drain properly from the sill area. Weep systems are designed to drain water to the exterior. If water does not drain quickly from the sill through the weep system, check the weep holes for blockage as follows:

1. Regularly clean sill track with vacuum or wipe thoroughly with damp cloth.

2. Pour small amount of water (1 cup) into interior sill track. If water drains through exterior weep holes or crevice, system is clear. If not, continue to Step 3 to clean.

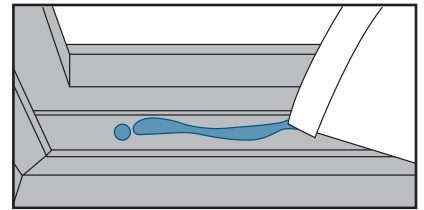

3. Insert thin wire into weep hole. Do not insert the wire farther than necessary to clear the blockage because the insulating glass unit may become damaged. Call us if unsure.
4. Repeat step one until water runs clear to the exterior. If not successful, call a service technician.

### EXTERIOR SIDING JOINT

A proper seal of the joint between the window and the exterior surface of the structure will provide a proper shield from the elements and will keep water and/or air from leaking into the home.

Inspect sealant in the joint for:

- Cracks
- Voids
- Deteriorating areas (e.g. loss of adhesion)

Repair damaged sealant with a best quality sealant.

**Note! Do not apply sealant to areas where installer or contractor did not originally seal. Seek professional advice from an installer or contractor if unsure.**

When repairing a sealant joint, 100% silicone sealant is the most durable, but it cannot be painted. Use 100% polyurethane sealant if painted. Follow sealant manufacturer's instructions for proper application.

## CLEANING GLASS SURFACES

Some window sashes may be removed (horizontal slider), tilted in (tilt single and double-hung), or opened (casements without egress hinges) for easier access to the exterior surface. For specific details on sash removal, please refer to the appropriate product guide for your window at [www.jeld-wen.com/resources](http://www.jeld-wen.com/resources).

### KeepCLEAN® Glass

If you have KeepCLEAN Glass (glass that's lower maintenance and easier to clean), make sure the glass surface has been properly activated. If not, the glass surface will not provide the easy-to-clean features for which it was designed. To activate, clean the exterior side of the glass with a solution of equal parts vinegar and water. The glass only needs to be activated once. KeepCLEAN Glass is available only in certain areas.

### GENERAL CLEANING

Prepare cleaning solution (1 tsp baby shampoo to one gallon of water or 1-1/2 cups vinegar to one gallon of water).

1. Rinse surface with clean water from top to bottom.
2. Clean with mild soap and water and sponge or soft brush with uniform pressure horizontally, then vertically.

**Note! Quickly rinse and dry any run-down. Don't allow cleaning solutions to collect or puddle on vinyl surfaces, crevices, etc.**

3. Promptly rinse thoroughly with clean water (sponging while rinsing may be helpful; do not allow cleaning solution to dry on the glass or vinyl surface).
4. Wipe dry with lint-free, dry cloth.
5. If necessary, repeat steps above until clean.
6. Dry window frame and sill with separate cloth.

### PAINT REMOVAL

1. Soak dried latex paint drips with warm water and baby shampoo solution.
2. Wipe with damp cloth or sponge.

If needed,

3. Scrape gently with plastic putty knife. Repeat soak and scrape.
4. Repeat if necessary.

**Note! For oil-based paint drips, consult local paint professional.**

### LABEL REMOVAL

Slowly peel from one corner. If label tears or sticks, moisten with soapy water and gently scrape with plastic putty knife. Stubborn labels can be soaked with soapy water and covered overnight with plastic wrap. Gently remove with plastic putty knife.

### STUBBORN STAIN REMOVAL

For stubborn stains, commercial glass cleaning products may be necessary.

- Apply small amount directly to the stain. Avoid spilling or dripping down the glass.
- Some persistent stains may need higher strength cleaning solutions that contain active ingredient chemicals such as toluene, xylene, mineral spirits or naphtha. Special care must be taken when using these types of cleaners. Avoid getting onto vinyl surfaces.
- For oil and grease, try baking soda and water or washing soda and water.
- Rinse thoroughly with clean water and dry.

### MORE INFORMATION ON GLASS CLEANING

- The Glass Association of North America (GANA): [www.glasswebsite.com](http://www.glasswebsite.com)
- Cardinal Glass Industries: [www.cardinalcorp.com](http://www.cardinalcorp.com)

**Note on Websites! Website content is subject to change and should be used for informational purposes only. JELD-WEN is not responsible for third-party information.**

## CLEANING VINYL SURFACES

Prepare cleaning solution (1 tsp baby shampoo to one gallon of water or 1 1/2 cups vinegar to one gallon of water).

1. Rinse surface with clean water from top to bottom.
2. Clean with mild soap and water and sponge or soft brush with uniform pressure horizontally, then vertically.

**Note! Quickly rinse and dry any run-down. Don't allow cleaning solutions to collect or puddle on vinyl surfaces, crevices, etc.**

3. Promptly rinse thoroughly with clean water (sponging while rinsing may be helpful; do not allow cleaning solution to dry on the glass or vinyl surface).
4. Wipe dry with lint-free, dry cloth.
5. If necessary, repeat steps above until clean.

## HARDWARE CLEANING & LUBRICATION

Cleaning and lubrication help to maintain and restore smooth operation to movable parts of windows and patio doors and, in most cases, offer corrosion protection. Always thoroughly clean hardware before lubricating.

Maintain hardware any time windows are not opening or closing properly or at least bi-annually (monthly for coastal areas) for the following:

- Clean dirt/debris
- Tighten loose screws
- Replace damaged hardware

### PRECAUTIONS

The following substances may damage protective hardware finishes. Do not use:

- Vinegar-based cleaners
- Citrus-based cleaners (lemon, etc.)
- Paint removers
- Window cleaners
- Brick/siding washes
- Any other industrial or abrasive cleaners

Use caution with silicone-based sprays. Apply only in small amounts and do not overspray. Wipe off excess lubricant to avoid staining and/or damage to other window or patio door parts. Silicone may cause some hard plastic parts to become brittle.

### HARDWARE TYPES

**Metal hardware** offers functionality, aesthetic appeal and resistance to corrosion but is not totally corrosion proof. Replace corroded hardware.

**Plastic hardware** offers high resistance to the elements; however, over time, can deteriorate from ultraviolet light, heat, cold, and chemical exposure.

## HARDWARE CLEANING

### General Cleaning

1. Remove hardware for easier cleaning.
2. Use mild soap and water on a soft cloth or sponge; rinse and wipe dry.  
**Note! For stubborn dirt, use a soft bristle brush to gently scrub.**
3. Apply several coats of high quality, non-abrasive car wax.
4. Reinstall hardware.

### Heavy Cleaning

Solvents, abrasives, and other cleaners could cause damage to protective coatings on hardware. If the general cleaning procedure is not sufficient, call us for recommendations.

## HARDWARE LUBRICATION

Different hardware parts need different types of lubricants.

### Suggested Lubricant Types

**White or Lithium Grease:**

Protects metal surfaces against corrosion, reduces friction and wear on moving parts, and is an excellent multi-purpose lubricant.

**Light Oil (such as 3-in-One®):**

Use for sliding or rotating joints.

**Graphite (spray black carbon powder):**

Use for door lock key ways and hinges.

**Note! Use care when applying graphite to prevent possible staining of parts.**

**Spray Silicone:**

Use for slider tracks, jamb liners, and weatherstrip.

**Note! Do not spray directly onto hardware surfaces.**

**Spray onto clean cloth to apply.**

### Butt Hinges

**Note! Butt hinges are located on swinging patio doors and some window styles.** Lubricate hinges with light oil (3-In-One® oil or equivalent) annually or when noisy.

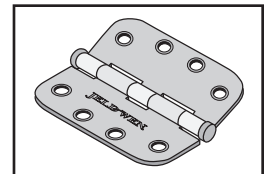

### Slider Tracks & Jamb Liners

Slider tracks or jamb liners can become dirty and difficult to operate. Clean and lubricate as follows:

1. Remove sash(es).
2. Vacuum track or wipe with a soft cloth.
3. Apply spray silicone to dry, soft cloth. Wipe onto track, jamb liner and/or weatherstrip. Do not apply silicone to pile (fuzzy) weatherstrip.
4. Reinstall sash(es) and check operation.

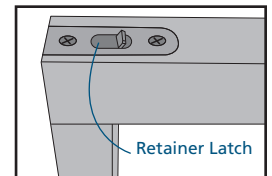

### Plastic Hardware

Most hard plastic hardware parts (e.g. sash retainer latches) require periodic cleaning for smooth operation and do not require lubrication.

**HARDWARE LUBRICATION – CONTINUED**

**Casement/Awning Hardware**

**Note!** New operators and hinges are already greased and oiled and should not need lubrication. Periodically lubricate operator gear mechanisms with white or lithium grease.

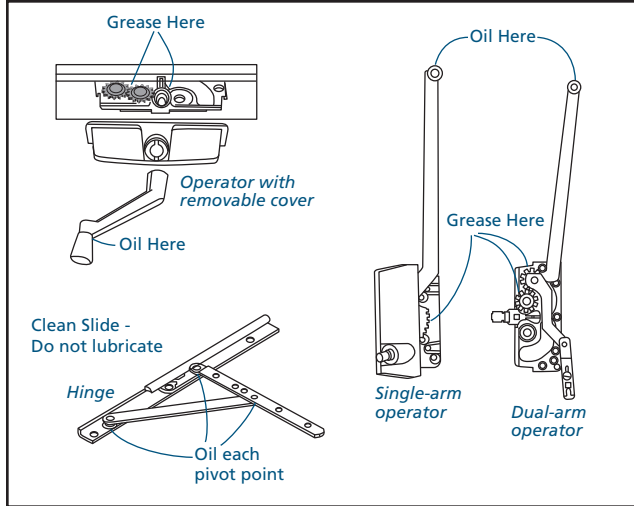

There are two types of operators with gear mechanisms:

- Removable cover
- Non-removable cover with the gears reachable through the back

For operators with removable covers:

**Note!** Some handle styles don't have screws and will just pull off.

1. Remove set screw on crank handle with small screwdriver or Allen wrench; remove handle.
2. Gently remove plastic cover (lift from the base).
3. Apply grease to gears and oil to joints.

For operators with non-removable covers:

1. Use a small mirror for a better view of the gears.
2. Apply grease/oil through back side of operator.

**Casement/Awning Rotating Joints**

Light oil provides lubrication for rotating joints such as hinge pivots. Spray lubricants or graphite are acceptable, but need frequent application.

1. Open window for access to joints.
2. Oil as shown.

**Patio Door Rollers & Multi-Point Locks**

**Removing patio door panels can be dangerous and should be performed by service personnel or at least with additional help.**

1. Remove door panel.
2. Tip door panel for access to rollers on the bottom.
3. Lubricate rollers where the shaft goes through the middle of the wheels with light oil.
4. Lightly oil multi-point lock at each latch point.
5. Spray keyway lock with graphite lubricant.

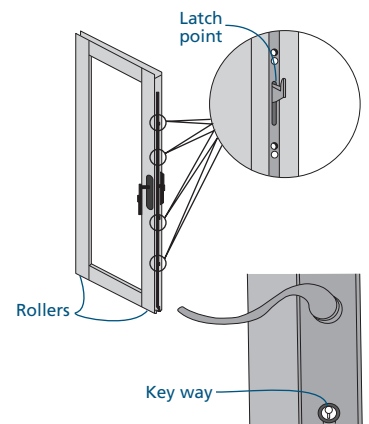

**GLOSSARY****Casement**

A window with a sash that opens from the side like a door.

**Double-Hung**

A window with an upper and lower sash that slide vertically past each other.

**Egress Hinge**

A hinge used in conjunction with certain casement windows to allow a wider opening to meet emergency exit requirements.

**Frame**

The assembly of structural members (head, sill and jambs) used to fasten the window/patio door to the structure.

**Grille**

A Decorative grid on the interior or exterior of the glass or between the glass panes.

**Insulated Glass Unit**

A sealed assembly of two or more panes of glass separated by a spacer.

**Jamb Liner**

A removable balance system that fits into the side jamb.

**Kerf**

A groove that often holds weatherstrip.

**Keyway**

The slot in the lock where the key is inserted.

**Patio Door Panel**

An assembly comprised of stiles (vertical pieces), rails (horizontal pieces) and the patio door's glass.

**Rail**

The horizontal piece of a sash or panel.

**Retainer Latch**

Secures sash into jamb to guide during operation. Releases to tilt for easy cleaning or removal.

**Sash**

An assembly comprised of stiles (vertical pieces), rails (horizontal pieces) and the window's glass.

**Seal Failure**

The airtight seal between two panes of an insulating glass unit has broken and is usually discovered when excess moisture fogs the inside of the glass panes.

**Side Jamb**

The vertical frame member on either side of the window or patio door.

**Sill**

The bottom horizontal frame member of a window.

**Sill Track**

The track on the sill of a sliding/gliding window or patio door that guides the sash as it opens and closes.

**Slider**

A window with one or more sashes that slide horizontally.

**Stile**

The vertical piece of a sash or panel.

**Weatherstrip**

A strip of material that covers the joint between two separate parts of a window or patio door and is used to prevent rain, snow and cold air from entering.

**Weep Hole**

The visible exit or entry part of a water drainage system used to drain water out of a window unit.

**INSPECTION CHECKLIST**

INSPECTION DATE \_\_\_\_/\_\_\_\_/\_\_\_\_

EXTERIOR	NOTES
<ul style="list-style-type: none"> <li>• Vinyl Surface                             <ul style="list-style-type: none"> <li><input type="checkbox"/> Dirty</li> <li><input type="checkbox"/> Cracks, scratches, blisters, other damage</li> </ul> </li> </ul>	
<ul style="list-style-type: none"> <li>• Sealant Joint                             <ul style="list-style-type: none"> <li><input type="checkbox"/> Cracks, voids, other damage</li> <li><input type="checkbox"/> Deterioration, loss of adhesion</li> </ul> </li> </ul>	
<ul style="list-style-type: none"> <li>• Glass                             <ul style="list-style-type: none"> <li><input type="checkbox"/> Dirty</li> <li><input type="checkbox"/> Scratched, cracked, other damage</li> </ul> </li> </ul>	
<ul style="list-style-type: none"> <li>• Weatherstrip                             <ul style="list-style-type: none"> <li><input type="checkbox"/> Missing or loose</li> <li><input type="checkbox"/> Tears, cracks, other damage</li> <li><input type="checkbox"/> Brittle, gummy, discolored</li> <li><input type="checkbox"/> No "bounce back"</li> </ul> </li> </ul>	
<ul style="list-style-type: none"> <li>• Insect Screen                             <ul style="list-style-type: none"> <li><input type="checkbox"/> Dirty</li> <li><input type="checkbox"/> Missing or loose</li> <li><input type="checkbox"/> Mesh damaged or loose</li> </ul> </li> </ul>	
<ul style="list-style-type: none"> <li>• Gutters                             <ul style="list-style-type: none"> <li><input type="checkbox"/> Dirty</li> <li><input type="checkbox"/> Damaged</li> <li><input type="checkbox"/> Missing</li> </ul> </li> </ul>	
<b>INTERIOR</b>	
<ul style="list-style-type: none"> <li>• Vinyl Surface                             <ul style="list-style-type: none"> <li><input type="checkbox"/> Dirty</li> <li><input type="checkbox"/> Scratched, cracked, other damage</li> </ul> </li> </ul>	
<ul style="list-style-type: none"> <li>• Glass                             <ul style="list-style-type: none"> <li><input type="checkbox"/> Dirty</li> <li><input type="checkbox"/> Moisture between Panes (insulating glass only)</li> </ul> </li> </ul>	
<ul style="list-style-type: none"> <li>• All Product Hardware                             <ul style="list-style-type: none"> <li><input type="checkbox"/> Dirty or damaged</li> <li><input type="checkbox"/> Discolored or tarnished</li> <li><input type="checkbox"/> Problems with sash locks</li> </ul> </li> </ul>	
<ul style="list-style-type: none"> <li>Casement/Awning Windows                             <ul style="list-style-type: none"> <li><input type="checkbox"/> Operators working properly</li> <li><input type="checkbox"/> Operators need lubrication</li> </ul> </li> </ul>	
<ul style="list-style-type: none"> <li>Double/Single-Hung Windows                             <ul style="list-style-type: none"> <li><input type="checkbox"/> Jamb liners damaged</li> <li><input type="checkbox"/> Sash balances fail to hold properly</li> <li><input type="checkbox"/> Problems with sash tilt latches</li> <li><input type="checkbox"/> Problems with cam pivots</li> </ul> </li> </ul>	
<ul style="list-style-type: none"> <li>Sliding/Gliding Windows                             <ul style="list-style-type: none"> <li><input type="checkbox"/> Track dirty</li> </ul> </li> </ul>	
<ul style="list-style-type: none"> <li>Patio doors                             <ul style="list-style-type: none"> <li><input type="checkbox"/> Track dirty</li> <li><input type="checkbox"/> Problems with rollers</li> <li><input type="checkbox"/> Problems with locks</li> <li><input type="checkbox"/> Locks or hinges need lubrication</li> </ul> </li> </ul>	